

Das meistverkaufte iglidur®-Gleitlager weltweit: Der Alleskönner – iglidur® G



über 650 Abmessungen ab Lager

wartungsfreier Trockenlauf

hohe Abriebfestigkeit

unempfindlich gegen Staub und Schmutz

kostengünstig

Das meistverkaufte iglidur®-Gleitlager weltweit. Der weiteste Bereich unterschiedlicher Anforderungen wird durch iglidur® G-Gleitlager abgedeckt. Deshalb wird der Werkstoff zu Recht als universell bezeichnet. Empfohlen werden Anwendungen mit mittleren bis hohen Belastungen, mittleren Gleitgeschwindigkeiten und mittleren Temperaturen.



Wann nehme ich es?

- Wenn ich ein wirtschaftliches Allroundlager brauche
- Bei hoher Belastung
- Bei niedrigen bis mittleren Gleitgeschwindigkeiten
- Wenn das Lager für unterschiedliche Wellen geeignet sein soll
- Bei Schwenk- und Rotationsanwendungen
- Wenn das Lager extrem vielseitig einsetzbar sein soll
- Wenn Trockenlauf gefordert ist
- Wenn das Lager unempfindlich gegen Schmutz sein soll
- Bei starken Schwingungen



Wann nehme ich es nicht?

- Wenn mechanische Nacharbeit der Gleitfläche erforderlich ist
▶ iglidur® M250, Seite 111
- Wenn allerhöchste Verschleißfestigkeit im Dauerbetrieb gefordert ist
▶ iglidur® W300, Seite 135
- Wenn Chemikalienbeständigkeit benötigt wird
▶ iglidur® X, Seite 157
- Wenn Temperaturen dauernd größer als +130 °C vorliegen
▶ iglidur® H, Seite 337
▶ iglidur® X, Seite 157
▶ iglidur® H370, Seite 359
- Bei Unter-Wasser-Einsatz
▶ iglidur® H, Seite 337

Temperatur

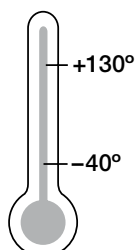

Lieferprogramm

3 Bauformen
> 650 Abmessungen
Ø 1,5–150 mm

iglidur® G | Anwendungsbeispiele



Typische Industriezweige und Anwendungsbereiche

- Agrar ● Baumaschinenindustrie
- Maschinenbau ● Sport und Freizeit
- Automobilindustrie u. v. m.

Technik verbessern und Kosten senken –
310 weitere spannende Anwendungsbeispiele
online ► www.igus.de/iglidurPraxis



► www.igus.de/heuschwader



► www.igus.de/fahrzeugbau



► www.igus.de/hinterradschwinge



► www.igus.de/holzbearbeitung

Materialeigenschaften

Allgemeine Eigenschaften	Einheit	iglidur® G	Prüfmethode
Dichte	g/cm ³	1,46	
Farbe		mattgrau	
max. Feuchtigkeitsaufnahme bei +23 °C/50 % r. F.	Gew.-%	0,7	DIN 53495
max. Wasseraufnahme	Gew.-%	4,0	
Gleitreibwert, dynamisch, gegen Stahl	μ	0,08–0,15	
pv-Wert, max. (trocken)	MPa · m/s	0,42	
Mechanische Eigenschaften			
Biege-E-Modul	MPa	7.800	DIN 53457
Biegefestigkeit bei +20 °C	MPa	210	DIN 53452
Druckfestigkeit	MPa	78	
maximal empfohlene Flächenpressung (+20 °C)	MPa	80	
Shore-D-Härte		81	DIN 53505
Physikalische und thermische Eigenschaften			
obere langzeitige Anwendungstemperatur	°C	+130	
obere kurzzeitige Anwendungstemperatur	°C	+220	
untere Anwendungstemperatur	°C	-40	
Wärmeleitfähigkeit	W/m · K	0,24	ASTM C 177
Wärmeausdehnungskoeffizient (bei +23 °C)	K ⁻¹ · 10 ⁻⁵	9	DIN 53752
Elektrische Eigenschaften			
spezifischer Durchgangswiderstand	Ωcm	> 10 ¹³	DIN IEC 93
Oberflächenwiderstand	Ω	> 10 ¹¹	DIN 53482

Tabelle 01: Materialeigenschaften



Abb. 01: Zulässige pv-Werte für iglidur® G-Gleitlager mit 1 mm Wandstärke im Trockenlauf gegen eine Stahlwelle, bei +20 °C, eingebaut in ein Stahlgehäuse

iglidur® G | Technische Daten

iglidur® G ist der Zehnkämpfer unter den iglidur® Materialien. In allen technischen Disziplinen außerordentlich gut und vor allem in der Summe der allgemeinen, mechanischen, thermischen und tribologischen Eigenschaften der klassische Allrounder.

Mechanische Eigenschaften

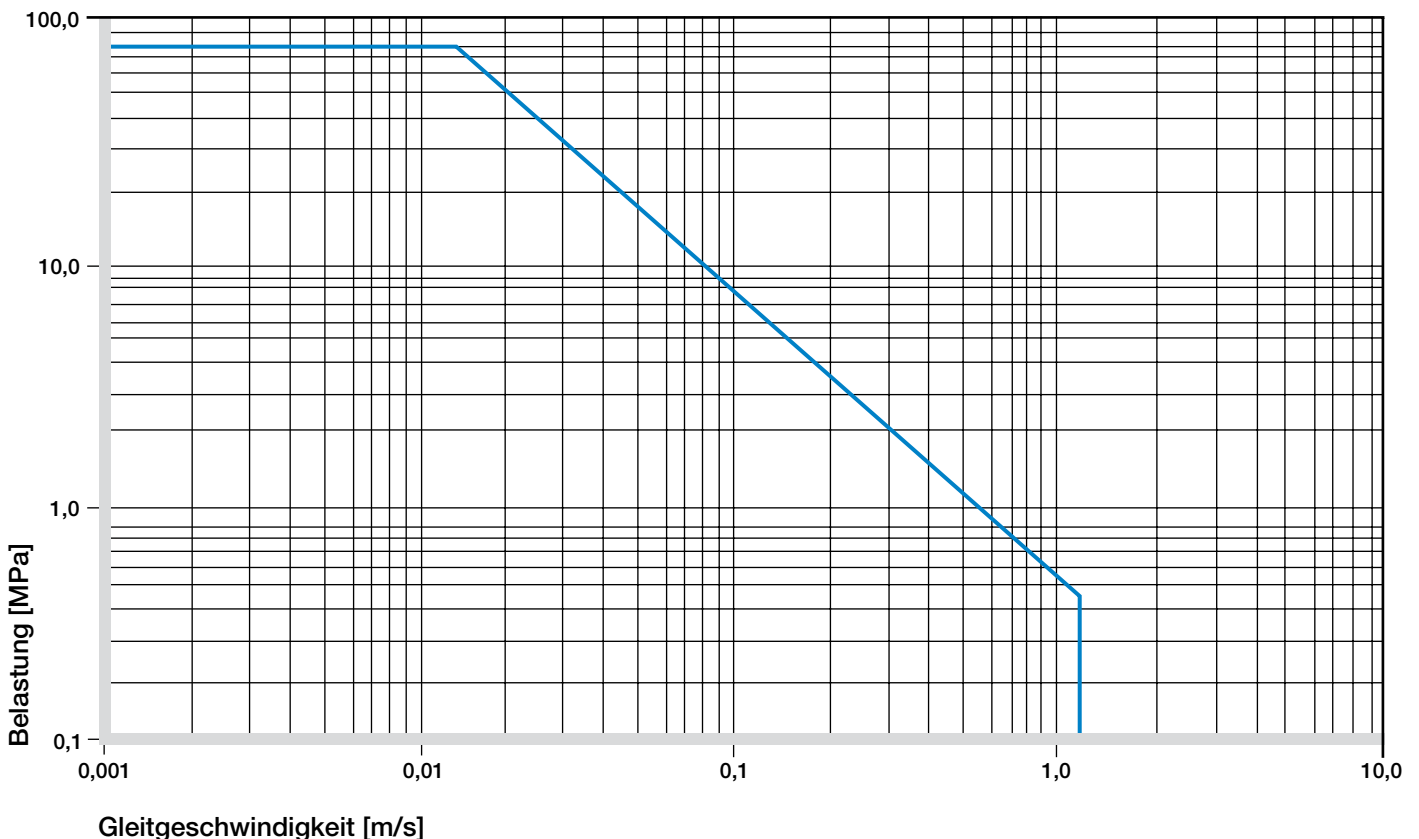
Mit steigenden Temperaturen nimmt die Druckfestigkeit von iglidur® G-Gleitlagern ab. Abb. 02 verdeutlicht diesen Zusammenhang. Bei der langfristig zulässigen Anwendungstemperatur von +130 °C beträgt die zulässige Flächenpressung nahezu 35 MPa. Die maximal empfohlene Flächenpressung stellt einen mechanischen Werkstoffkennwert dar. Rückschlüsse auf die Tribologie können daraus nicht gezogen werden.



Abb. 02: Maximal empfohlene Flächenpressung in Abhängigkeit von der Temperatur (80 MPa bei +20 °C)

Abb. 03 zeigt die elastische Verformung von iglidur® G bei radialen Belastungen. Unter der maximal empfohlenen Flächenpressung von 80 MPa beträgt die Verformung weniger als 4%. Eine plastische Verformung kann bis zu einem Druck von ca. 100 MPa vernachlässigt werden. Sie ist jedoch auch von der Dauer der Einwirkung abhängig.

► Flächenpressung, Seite 47

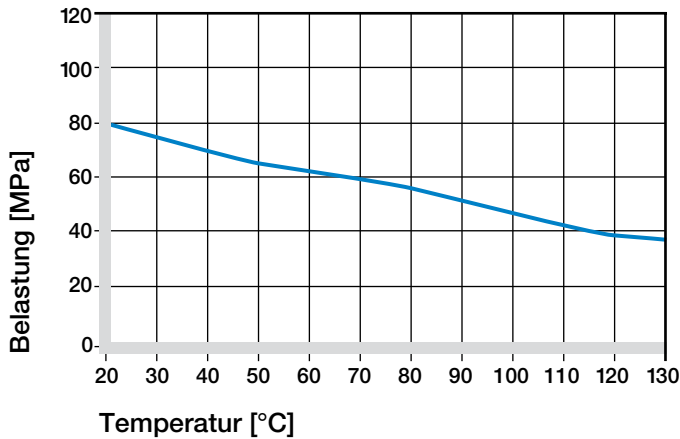

Abb. 03: Verformung unter Belastung und Temperaturen

Zulässige Gleitgeschwindigkeiten

iglidur® G wurde für niedrige bis mittlere Gleitgeschwindigkeiten entwickelt.

Die in Tabelle 02 angegebenen Maximalwerte können nur bei geringen Druckbelastungen erreicht werden. Bei den angegebenen Geschwindigkeiten kann es aufgrund von Reibung zu einem Anstieg bis zur Grenze der dauerhaft zulässigen Temperatur kommen. In der Praxis lassen sich aufgrund von Wechselwirkungen unterschiedlicher Einflüsse diese Grenzwerte nicht immer erreichen.

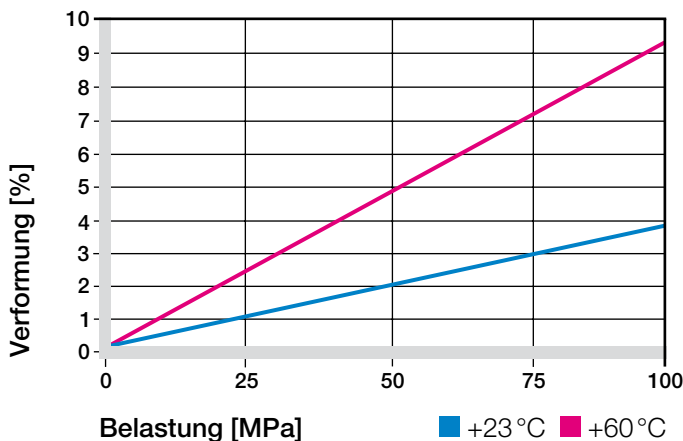
► Gleitgeschwindigkeit, Seite 49

m/s	rotierend	oszillierend	linear
dauerhaft	1	0,7	4
kurzzeitig	2	1,4	5

Tabelle 02: Maximale Gleitgeschwindigkeit

Temperaturen

Die Umgebungstemperaturen beeinflussen in starkem Maß die Eigenschaften von Gleitlagern.

Die kurzzeitige zulässige Höchsttemperatur beträgt +220 °C und erlaubt damit den Einsatz von iglidur® G-Gleitlagern in Anwendungen, bei denen die Lager ohne weitere Belastung zum Beispiel einem Lackiertrocknungsprozess unterzogen werden.

Die im Lagersystem herrschenden Temperaturen haben auch Einfluss auf den Lagerverschleiß. Mit steigenden Temperaturen nimmt der Verschleiß zu, dabei ist ab der Temperatur von +120 °C der Einfluss besonders deutlich.

► Anwendungstemperaturen, Seite 50

iglidur® G	Anwendungstemperatur
untere	-40 °C
obere, langfristig	+130 °C
obere, kurzzeitig	+220 °C
zus. axial zu sichern ab	+80 °C

Tabelle 03: Temperaturgrenzen

Reibung und Verschleiß

Wie die Verschleißfestigkeit ändert sich mit der Belastung auch der Reibungsbeiwert μ , kurz Reibwert genannt. Interessanterweise nimmt der Reibwert mit zunehmender Belastung ab, während eine zunehmende Gleitgeschwindigkeit ein Ansteigen des Reibwertes bewirkt. Dieser Zusammenhang erklärt die hervorragende Eignung von iglidur® G-Gleitlagern bei hohen Belastungen und niedrigen Geschwindigkeiten (Abb. 04 und 05).

► Reibwerte und Oberflächen, **Seite 52**

► Verschleißfestigkeit, **Seite 53**



Abb. 04: Reibwerte in Abhängigkeit von der Gleitgeschwindigkeit, $p = 0,75 \text{ MPa}$



Abb. 05: Reibwerte in Abhängigkeit von der Belastung, $v = 0,01 \text{ m/s}$

Wellenwerkstoffe

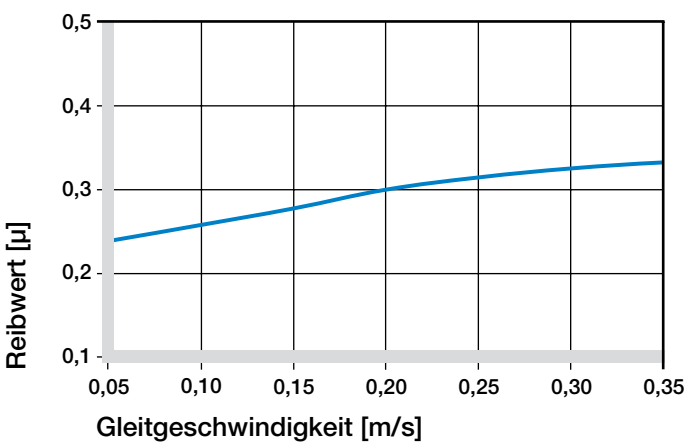
Reibung und Verschleiß sind auch in hohem Maße vom Gegenlaufpartner abhängig. Zu glatte Wellen erhöhen sowohl den Reibwert als auch den Verschleiß der Lager. Für iglidur® G eignet sich am besten eine geschliffene Oberfläche mit einer Mittenrauigkeit $R_a = 0,8 \mu\text{m}$ (Abb. 06). Abb. 07 bis 09 zeigen einen Auszug der Ergebnisse von Tests mit unterschiedlichen Wellenwerkstoffen, die mit iglidur® G-Gleitlagern durchgeführt worden sind.

In Abb. 07 ist zu erkennen, dass iglidur® G mit sehr vielen unterschiedlichen Wellenwerkstoffen kombiniert werden kann. Am besten haben sich bei niedrigen Belastungen die einfachen Wellenwerkstoffe Automatenstahl und St37 bewährt. Das unterstützt den Aufbau kostengünstiger Lagersysteme, denn sowohl iglidur® G als auch die Gleitpartner liegen am unteren Ende des Preisbandes.

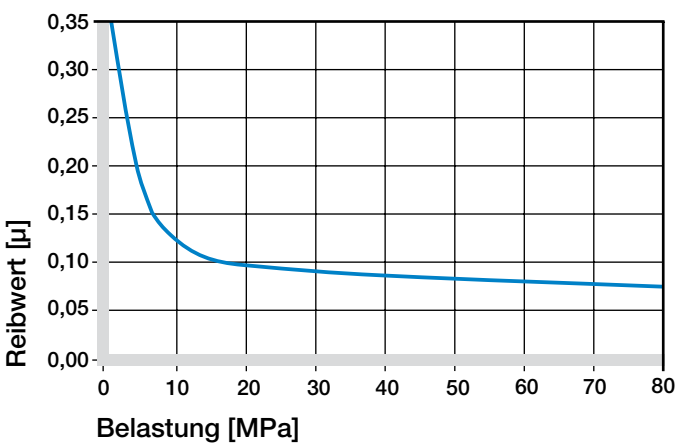
In diesem Zusammenhang ist es wichtig, zu beachten, dass mit steigenden Belastungen die empfohlene Härte der Welle zunimmt. Die „weichen“ Wellen neigen eher zum Eigenverschleiß und erhöhen so den Verschleiß des Gesamtsystems, wenn die Belastungen 2 MPa übersteigen. Der Vergleich von rotierenden mit schwenkenden Bewegungen zeigt, dass iglidur® G besonders vorteilhaft in Schwenkbewegungen eingesetzt wird. Der Verschleiß der Lager ist bei sonst gleichen Bedingungen geringer. Je höher die Belastung wird, desto größer ist der Unterschied.

Falls der von Ihnen vorgesehene Wellenwerkstoff in den hier vorgestellten Versuchsergebnissen nicht enthalten ist, sprechen Sie uns bitte an.

► Wellenwerkstoffe, **Seite 55**



Abb. 06: Reibwerte in Abhängigkeit von der Wellenoberfläche (Welle Cf53)

iglidur® G | Technische Daten



Abb. 07: Verschleiß, rotierende Anwendung mit unterschiedlichen Wellenwerkstoffen, Belastung $p = 1 \text{ MPa}$, $v = 0,3 \text{ m/s}$

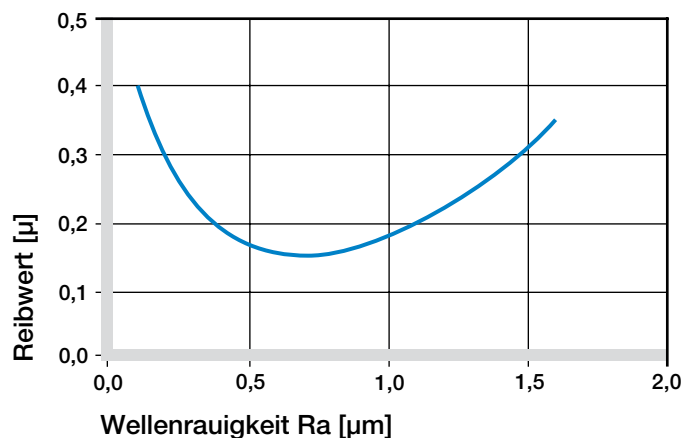

Abb. 08: Verschleiß mit verschiedenen Wellenwerkstoffen im Rotationsbetrieb in Abhängigkeit von der Belastung

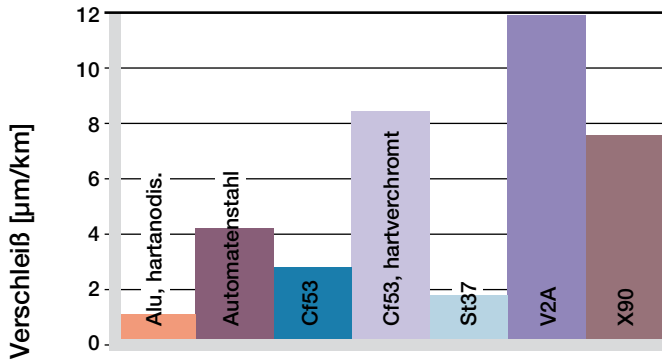

Abb. 09: Verschleiß bei oszillierenden und rotierenden Anwendungen mit Wellenwerkstoff Cf53 in Abhängigkeit von der Belastung

iglidur® G	trocken	Fett	Öl	Wasser
Reibwerte μ	0,08–0,15	0,09	0,04	0,04

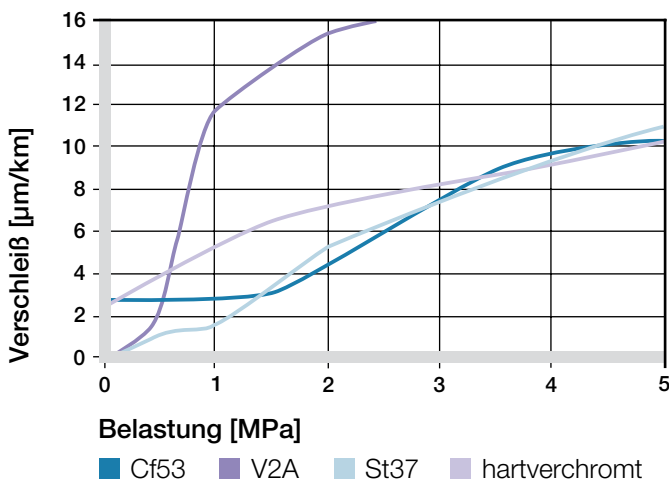
Tabelle 04: Reibwerte gegen Stahl ($Ra = 1 \text{ µm}$, 50 HRC)

Weitere Eigenschaften

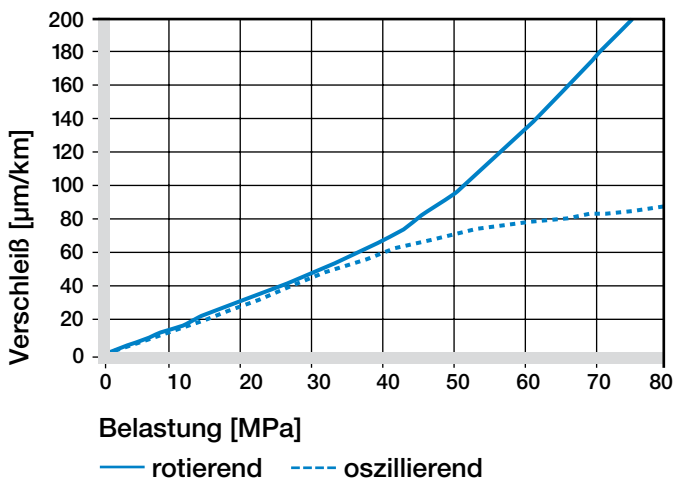
Chemikalienbeständigkeit

iglidur® G-Gleitlager haben bei Raumtemperatur eine gute Beständigkeit gegen Chemikalien. Sie sind gegen die meisten Schmierstoffe beständig.

Von den meisten schwachen organischen und anorganische Säuren wird iglidur® G nicht angegriffen.

► Chemikaliientabelle, Seite 1118

Medium	Beständigkeit
Alkohole	+ bis 0
Kohlenwasserstoffe	+
Fette, Öle, nicht additiviert	+
Kraftstoffe	+
verdünnte Säuren	0 bis –
starke Säuren	–
verdünnte Basen	+
starke Basen	0

+ beständig 0 bedingt beständig – unbeständig

Alle Angaben bei Raumtemperatur [$+20 \text{ °C}$]

Tabelle 05: Chemikalienbeständigkeit

Radioaktive Strahlen

Gleitlager aus iglidur® G sind strahlenbeständig bis zu einer Strahlungsintensität von $3 \cdot 10^2 \text{ Gy}$.

UV-Beständigkeit

iglidur® G-Gleitlager sind gegen UV-Strahlen dauerhaft beständig.

Vakuum

Im Vakuum gasen iglidur® G-Gleitlager aus. Der Einsatz im Vakuum ist nur für trockene Lager möglich.

Elektrische Eigenschaften

iglidur® G-Gleitlager sind elektrisch isolierend.

spezifischer Durchgangswiderstand $> 10^{13} \text{ Ωcm}$

Oberflächenwiderstand $> 10^{11} \text{ Ω}$

Feuchtigkeitsaufnahme

Die Feuchtigkeitsaufnahme von iglidur® G-Gleitlagern beträgt im Normalklima etwa 0,7 %. Die Sättigungsgrenze im Wasser liegt bei 4 %. Dies muss bei entsprechenden Einsatzbedingungen berücksichtigt werden.

Maximale Feuchtigkeitsaufnahme

bei +23 °C/50 % r. F. 0,7 Gew.-%

max. Wasseraufnahme 4,0 Gew.-%

Tabelle 06: Feuchtigkeitsaufnahme



Abb. 10: Einfluss der Feuchtigkeitsaufnahme

Einbautoleranzen

iglidur® G-Gleitlager sind Standardlager für Wellen mit h-Toleranz (empfohlen mindestens h9). Die Lager sind ausgelegt für das Einpressen in eine H7-tolerierte Aufnahme. Nach dem Einbau in eine Aufnahme mit Nennmaß stellt sich der Innendurchmesser der Lager im Standardfall mit E10-Toleranz selbstständig ein. Bei bestimmten Abmessungen weicht die Toleranz in Abhängigkeit von der Wandstärke hier von ab (siehe Lieferprogramm).

► Prüfverfahren, Seite 59

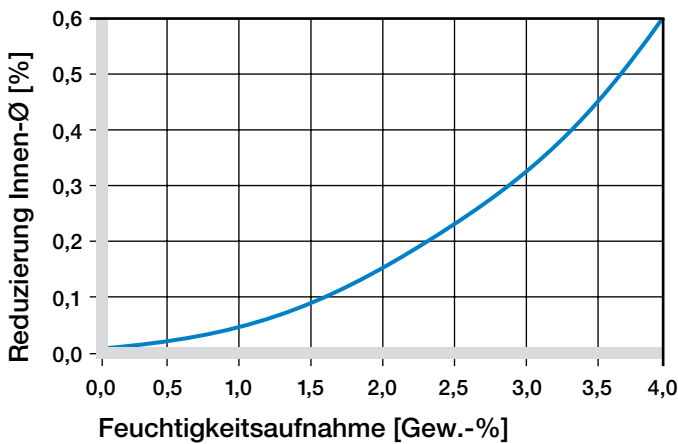
Durchmesser d1 [mm]	Welle h9 [mm]	iglidur® G E10 [mm]	Gehäuse H7 [mm]
bis 3	0-0,025	+0,014 +0,054	0 +0,010
> 3 bis 6	0-0,030	+0,020 +0,068	0 +0,012
> 6 bis 10	0-0,036	+0,025 +0,083	0 +0,015
> 10 bis 18	0-0,043	+0,032 +0,102	0 +0,018
> 18 bis 30	0-0,052	+0,040 +0,124	0 +0,021
> 30 bis 50	0-0,062	+0,050 +0,150	0 +0,025
> 50 bis 80	0-0,074	+0,060 +0,180	0 +0,030
> 80 bis 120	0-0,087	+0,072 +0,212	0 +0,035
> 120 bis 180	0-0,100	+0,085 +0,245	0 +0,040

Tabelle 07: Wichtige Toleranzen nach ISO 3547-1 nach dem Einpressen

iglidur® G | Lieferprogramm

zylindrische Gleitlager

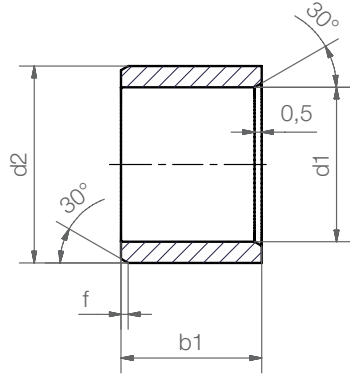

Abmessungen nach ISO 3547-1 und Sonderabmessungen

Fase in Abhängigkeit von d1

d1 [mm]:	Ø 1-6	Ø 6-12	Ø 12-30	Ø > 30
f [mm]:	0,3	0,5	0,8	1,2

Abmessungen [mm]

Bestellnummer	d1	d1-Toleranz*	d2	b1 h13
GSM-0103-02	1,5	+0,014 +0,054	3,0	2,0
GSM-0203-03	2,0	+0,014 +0,054	3,5	3,0
GSM-02504-05	2,5	+0,014 +0,054	4,5	5,0
GSM-0304-03	3,0	+0,014 +0,054	4,5	3,0
GSM-0304-05	3,0	+0,014 +0,054	4,5	5,0
GSM-0304-06	3,0	+0,014 +0,054	4,5	6,0
GSM-0405-04	4,0	+0,020 +0,068	5,5	4,0
GSM-0405-06	4,0	+0,020 +0,068	5,5	6,0
GSM-0406-08	4,5	+0,020 +0,068	6,0	8,0
GSM-0407-05	4,0	+0,020 +0,068	7,0	5,5
GSM-0506-046	5,0	+0,010 +0,040	6,0	4,6
GSM-0506-05	5,0	+0,010 +0,040	6,0	5,0
GSM-0506-07	5,0	+0,010 +0,040	6,0	7,0
GSM-0507-05	5,0	+0,020 +0,068	7,0	5,0
GSM-0507-07	5,0	+0,020 +0,068	7,0	7,0
GSM-0507-08	5,0	+0,020 +0,068	7,0	8,0
GSM-0507-10	5,0	+0,020 +0,068	7,0	10,0
GSM-0607-06	6,0	+0,010 +0,040	7,0	6,0
GSM-0607-12	6,0	+0,010 +0,040	7,0	12,0
GSM-0607-17	6,0	+0,010 +0,040	7,0	17,0
GSM-0607-17.5	6,0	+0,010 +0,040	7,0	17,5
GSM-0607-19	6,0	+0,010 +0,040	7,0	19,0
GSM-0608-015	6,0	+0,020 +0,068	8,0	1,5
GSM-0608-025	6,0	+0,020 +0,068	8,0	2,5
GSM-0608-03	6,0	+0,020 +0,068	8,0	3,0



Bestellschlüssel

GSM-0103-02

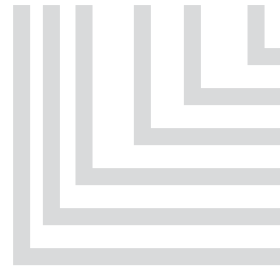

- Gesamtlänge b1
- Außendurchmesser d2
- Innendurchmesser d1
- metrisch
- zylindrisch (Form S)
- Werkstoff iglidur® G

Bestellnummer	d1	d1-Toleranz*	d2	b1 h13
GSM-0608-04	6,0	+0,020 +0,068	8,0	4,0
GSM-0608-05	6,0	+0,020 +0,068	8,0	5,0
GSM-0608-055	6,0	+0,020 +0,068	8,0	5,5
GSM-0608-06	6,0	+0,020 +0,068	8,0	6,0
GSM-0608-08	6,0	+0,020 +0,068	8,0	8,0
GSM-0608-09	6,0	+0,020 +0,068	8,0	9,5
GSM-0608-10	6,0	+0,020 +0,068	8,0	10,0
GSM-0608-11	6,0	+0,020 +0,068	8,0	11,8
GSM-0608-13	6,0	+0,020 +0,068	8,0	13,8
GSM-0708-10	7,0	+0,013 +0,049	8,0	10,0
GSM-0708-19	7,0	+0,013 +0,049	8,0	19,0
GSM-0709-08	7,0	+0,025 +0,083	9,0	8,0
GSM-0709-09	7,0	+0,025 +0,083	9,0	9,0
GSM-0709-10	7,0	+0,025 +0,083	9,0	10,0
GSM-0709-12	7,0	+0,025 +0,083	9,0	12,0
GSM-0809-05	8,0	+0,013 +0,049	9,0	5,0
GSM-0809-06	8,0	+0,013 +0,049	9,0	6,0
GSM-0809-08	8,0	+0,013 +0,049	9,0	8,0
GSM-0809-12	8,0	+0,013 +0,049	9,0	12,0
GSM-0810-05	8,0	+0,025 +0,083	10,0	5,0
GSM-0810-06	8,0	+0,025 +0,083	10,0	6,0
GSM-0810-07	8,0	+0,025 +0,083	10,0	6,8
GSM-0810-08	8,0	+0,025 +0,083	10,0	8,0
GSM-0810-10	8,0	+0,025 +0,083	10,0	10,0
GSM-0810-12	8,0	+0,025 +0,083	10,0	12,0

* nach dem Einpressen; Messverfahren ► Seite 59



Lieferzeit ab Lager



Preise Online-Preisliste

www.igus.de/de/g



zylindrische Gleitlager

Abmessungen [mm]

Bestellnummer	d1	d1-Toleranz*	d2	b1 h13
GSM-0810-13	8,0	+0,025 +0,083	10,0	13,8
GSM-0810-15	8,0	+0,025 +0,083	10,0	15,0
GSM-0810-16	8,0	+0,025 +0,083	10,0	16,0
GSM-0810-20	8,0	+0,025 +0,083	10,0	20,0
GSM-0810-22	8,0	+0,025 +0,083	10,0	22,0
GSM-0810-25	8,0	+0,025 +0,083	10,1	25,0
GSM-0812-09	8,0	+0,040 +0,130	12,0	9,0
GSM-0910-12	9,0	+0,013 +0,049	10,0	12,0
GSM-0910-16	9,0	+0,013 +0,049	10,0	16,0
GSM-0911-06	9,0	+0,025 +0,083	11,0	6,0
GSM-0911-20	9,0	+0,025 +0,083	11,0	20,0
GSM-1011-06	10,0	+0,013 +0,049	11,0	6,0
GSM-1011-07	10,0	+0,013 +0,049	11,0	7,0
GSM-1011-10	10,0	+0,013 +0,049	11,0	10,0
GSM-1011-20	10,0	+0,013 +0,049	11,0	20,0
GSM-1011-25	10,0	+0,013 +0,049	11,0	25,0
GSM-1011-30	10,0	+0,013 +0,049	11,0	30,0
GSM-1012-04	10,0	+0,025 +0,083	12,0	4,0
GSM-1012-045	10,0	+0,025 +0,083	12,0	4,5
GSM-1012-05	10,0	+0,025 +0,083	12,0	5,0
GSM-1012-06	10,0	+0,025 +0,083	12,0	6,0
GSM-1012-07	10,0	+0,025 +0,083	12,0	7,0
GSM-1012-08	10,0	+0,025 +0,083	12,0	8,0
GSM-1012-09	10,0	+0,025 +0,083	12,0	9,0
GSM-1012-10	10,0	+0,025 +0,083	12,0	10,0
GSM-1012-12	10,0	+0,025 +0,083	12,0	12,0
GSM-1012-14	10,0	+0,025 +0,083	12,0	14,0
GSM-1012-15	10,0	+0,025 +0,083	12,0	15,0
GSM-1012-17	10,0	+0,025 +0,083	12,0	17,0
GSM-1012-20	10,0	+0,025 +0,083	12,0	20,0
GSM-1013-13	10,0	+0,025 +0,083	13,0	13,5
GSM-1014-10	10,0	+0,025 +0,115	14,0	10,0
GSM-1014-20	10,0	+0,025 +0,115	14,0	20,0
GSM-1016-10	10,0	+0,040 +0,130	16,0	10,0
GSM-1213-047	12,0	+0,016 +0,059	13,0	4,7
GSM-1213-10	12,0	+0,016 +0,059	13,0	10,0
GSM-1213-12	12,0	+0,016 +0,059	13,0	12,0
GSM-1213-15	12,0	+0,016 +0,059	13,0	15,0
GSM-1214-04	12,0	+0,032 +0,102	14,0	4,0
GSM-1214-05	12,0	+0,032 +0,102	14,0	5,0
GSM-1214-06	12,0	+0,032 +0,102	14,0	6,0
GSM-1214-08	12,0	+0,032 +0,102	14,0	8,0

Bestellnummer	d1	d1-Toleranz*	d2	b1 h13
GSM-1214-10	12,0	+0,032 +0,102	14,0	10,0
GSM-1214-12	12,0	+0,032 +0,102	14,0	12,0
GSM-1214-14	12,0	+0,032 +0,102	14,0	14,0
GSM-1214-15	12,0	+0,032 +0,102	14,0	15,0
GSM-1214-20	12,0	+0,032 +0,102	14,0	20,0
GSM-1214-25	12,0	+0,032 +0,102	14,0	25,0
GSM-1215-06	12,0	+0,032 +0,102	15,0	6,0
GSM-1215-22	12,0	+0,032 +0,102	15,0	22,0
GSM-1216-10	12,0	+0,050 +0,160	16,0	10,0
GSM-1216-20	12,0	+0,050 +0,160	16,0	20,0
GSM-1315-070	13,0	+0,032 +0,102	15,0	7,0
GSM-1315-075	13,0	+0,032 +0,102	15,0	7,5
GSM-1315-10	13,0	+0,032 +0,102	15,0	10,0
GSM-1315-15	13,0	+0,032 +0,102	15,0	15,0
GSM-1315-20	13,0	+0,032 +0,102	15,0	20,0
GSM-1315-25	13,0	+0,032 +0,102	15,0	25,0
GSM-1416-03	14,0	+0,032 +0,102	16,0	3,0
GSM-1416-06	14,0	+0,032 +0,102	16,0	6,0
GSM-1416-08	14,0	+0,032 +0,102	16,0	8,0
GSM-1416-10	14,0	+0,032 +0,102	16,0	10,0
GSM-1416-12	14,0	+0,032 +0,102	16,0	12,0
GSM-1416-15	14,0	+0,032 +0,102	16,0	15,0
GSM-1416-20	14,0	+0,032 +0,102	16,0	20,0
GSM-1416-25	14,0	+0,032 +0,102	16,0	25,0
GSM-1416-45	14,0	+0,032 +0,102	16,0	45,0
GSM-1516-10	15,0	+0,016 +0,059	16,0	10,0
GSM-1516-15	15,0	+0,016 +0,059	16,0	15,0
GSM-1517-04	15,0	+0,032 +0,102	17,0	4,0
GSM-1517-10	15,0	+0,032 +0,102	17,0	10,0
GSM-1517-12	15,0	+0,032 +0,102	17,0	12,0
GSM-1517-15	15,0	+0,032 +0,102	17,0	15,0
GSM-1517-20	15,0	+0,032 +0,102	17,0	20,0
GSM-1517-25	15,0	+0,032 +0,102	17,0	25,0
GSM-1618-055	16,0	+0,032 +0,102	18,0	5,5
GSM-1618-08	16,0	+0,032 +0,102	18,0	8,0
GSM-1618-10	16,0	+0,032 +0,102	18,0	10,0
GSM-1618-12	16,0	+0,032 +0,102	18,0	12,0
GSM-1618-13.5	16,0	+0,032 +0,102	18,0	13,5
GSM-1618-15	16,0	+0,032 +0,102	18,0	15,0
GSM-1618-20	16,0	+0,032 +0,102	18,0	20,0
GSM-1618-25	16,0	+0,032 +0,102	18,0	25,0
GSM-1618-30	16,0	+0,032 +0,102	18,0	30,0

* nach dem Einpressen; Messverfahren ► Seite 59

Abmessungen [mm]

Bestellnummer	d1	d1-Toleranz*	d2	b1 h13
GSM-1618-50	16,0	+0,032 +0,102	18,0	50,0
GSM-1819-15	18,0	+0,016 +0,059	19,0	15,0
GSM-1820-06	18,0	+0,032 +0,102	20,0	6,0
GSM-1820-10	18,0	+0,032 +0,102	20,0	10,0
GSM-1820-12	18,0	+0,032 +0,102	20,0	12,0
GSM-1820-15	18,0	+0,032 +0,102	20,0	15,0
GSM-1820-20	18,0	+0,032 +0,102	20,0	20,0
GSM-1820-25	18,0	+0,032 +0,102	20,0	25,0
GSM-1820-34	18,0	+0,032 +0,102	20,0	34
GSM-1820-38	18,0	+0,032 +0,102	20,0	38
GSM-1820-45	18,0	+0,032 +0,102	20,0	45,0
GSM-1822-30	18,0	+0,032 +0,102	22,0	30,0
GSM-1922-06	19,0	+0,040 +0,124	22,0	6,0
GSM-1922-28	19,0	+0,040 +0,124	22,0	28,0
GSM-1922-35	19,0	+0,040 +0,124	22,0	35,0
GSM-2021-20	20,0	+0,020 +0,072	21,0	20,0
GSM-2022-03	20,0	+0,040 +0,124	22,0	3,0
GSM-2022-08	20,0	+0,040 +0,124	22,0	8,0
GSM-2022-105	20,0	+0,040 +0,124	22,0	10,5
GSM-2022-15	20,0	+0,040 +0,124	22,0	15,0
GSM-2022-20	20,0	+0,040 +0,124	22,0	20,0
GSM-2022-22	20,0	+0,040 +0,124	22,0	22,0
GSM-2022-28	20,0	+0,040 +0,124	22,0	28,0
GSM-2022-30	20,0	+0,040 +0,124	22,0	30,0
GSM-2022-47	20,0	+0,040 +0,124	22,0	47,0
GSM-2023-10	20,0	+0,040 +0,124	23,0	10,0
GSM-2023-15	20,0	+0,040 +0,124	23,0	15,0
GSM-2023-20	20,0	+0,040 +0,124	23,0	20,0
GSM-2023-23	20,0	+0,040 +0,124	23,0	23,0
GSM-2023-24	20,0	+0,040 +0,124	23,0	24,0
GSM-2023-25	20,0	+0,040 +0,124	23,0	25,0
GSM-2023-30	20,0	+0,040 +0,124	23,0	30,0
GSM-2023-35	20,0	+0,040 +0,124	23,0	35,0
GSM-2224-08	22,0	+0,040 +0,124	24,0	8,0
GSM-2224-10	22,0	+0,040 +0,124	24,0	10,0
GSM-2224-12	22,0	+0,040 +0,124	24,0	12,0
GSM-2224-15	22,0	+0,040 +0,124	24,0	15,0
GSM-2224-17	22,0	+0,040 +0,124	24,0	17,0
GSM-2224-20	22,0	+0,040 +0,124	24,0	20,0
GSM-2224-30	22,0	+0,040 +0,124	24,0	30,0
GSM-2224-48	22,0	+0,040 +0,124	24,0	48,0

Bestellnummer	d1	d1-Toleranz*	d2	b1 h13
GSM-2225-15	22,0	+0,040 +0,124	25,0	15,0
GSM-2225-20	22,0	+0,040 +0,124	25,0	20,0
GSM-2225-25	22,0	+0,040 +0,124	25,0	25,0
GSM-2225-30	22,0	+0,040 +0,124	25,0	30,0
GSM-2425-25	24,0	+0,020 +0,072	25,0	25,0
GSM-2427-06	24,0	+0,040 +0,124	27,0	6,0
GSM-2427-15	24,0	+0,040 +0,124	27,0	15,0
GSM-2427-20	24,0	+0,040 +0,124	27,0	20,0
GSM-2427-24	24,0	+0,040 +0,124	27,0	24,0
GSM-2427-25	24,0	+0,040 +0,124	27,0	25,0
GSM-2427-30	24,0	+0,040 +0,124	27,0	30,0
GSM-2526-23	25,0	+0,020 +0,072	26,0	23,0
GSM-2526-25	25,0	+0,020 +0,072	26,0	25,0
GSM-2528-12	25,0	+0,040 +0,124	28,0	12,0
GSM-2528-15	25,0	+0,040 +0,124	28,0	15,0
GSM-2528-20	25,0	+0,040 +0,124	28,0	20,0
GSM-2528-24	25,0	+0,040 +0,124	28,0	24,0
GSM-2528-25	25,0	+0,040 +0,124	28,0	25,0
GSM-2528-30	25,0	+0,040 +0,124	28,0	30,0
GSM-2528-35	25,0	+0,040 +0,124	28,0	35,0
GSM-2528-50	25,0	+0,040 +0,124	28,0	50,0
GSM-2630-16	26,0	+0,040 +0,124	30,0	16,0
GSM-2730-05	27,0	+0,040 +0,124	30,0	5,0
GSM-2832-105	28,0	+0,040 +0,124	32,0	10,5
GSM-2832-12	28,0	+0,040 +0,124	32,0	12,0
GSM-2832-15	28,0	+0,040 +0,124	32,0	15,0
GSM-2832-20	28,0	+0,040 +0,124	32,0	20,0
GSM-2832-23	28,0	+0,040 +0,124	32,0	23,0
GSM-2832-25	28,0	+0,040 +0,124	32,0	25,0
GSM-2832-30	28,0	+0,040 +0,124	32,0	30,0
GSM-2835-19	28,0	+0,065 +0,195	35,0	19,0
GSM-2835-28	28,0	+0,065 +0,195	35,0	28,0
GSM-2933-06	29,0	+0,040 +0,124	33,0	6,0
GSM-3031-05	30,0	+0,020 +0,072	31,0	5,0
GSM-3031-12	30,0	+0,020 +0,072	31,0	12,0
GSM-3031-30	30,0	+0,020 +0,072	31,0	30,0
GSM-3034-15	30,0	+0,040 +0,124	34,0	15,0
GSM-3034-20	30,0	+0,040 +0,124	34,0	20,0
GSM-3034-24	30,0	+0,040 +0,124	34,0	24,0
GSM-3034-25	30,0	+0,040 +0,124	34,0	25,0
GSM-3034-30	30,0	+0,040 +0,124	34,0	30,0

* nach dem Einpressen; Messverfahren ► Seite 59

Lieferzeit ab Lager

Preise Online-Preisliste
www.igus.de/de/g



zylindrische Gleitlager

Abmessungen [mm]

Bestellnummer	d1	d1-Toleranz*	d2	b1 h13
GSM-3034-35	30,0	+0,040 +0,124	34,0	35,0
GSM-3034-40	30,0	+0,040 +0,124	34,0	40,0
GSM-3034-525	30,0	+0,040 +0,124	34,0	52,5
GSM-3236-15	32,0	+0,050 +0,150	36,0	15,0
GSM-3236-20	32,0	+0,050 +0,150	36,0	20,0
GSM-3236-30	32,0	+0,050 +0,150	36,0	30,0
GSM-3236-40	32,0	+0,050 +0,150	36,0	40,0
GSM-3539-14	35,0	+0,050 +0,150	39,0	14,0
GSM-3539-20	35,0	+0,050 +0,150	39,0	20,0
GSM-3539-25	35,0	+0,050 +0,150	39,0	25,0
GSM-3539-30	35,0	+0,050 +0,150	39,0	30,0
GSM-3539-40	35,0	+0,050 +0,150	39,0	40,0
GSM-3539-50	35,0	+0,050 +0,150	39,0	50,0
GSM-3541-50	35,0	+0,050 +0,150	41,0	50,0
GSM-3640-20	36,0	+0,050 +0,150	40,0	20,0
GSM-3741-20	37,0	+0,050 +0,150	41,0	20,0
GSM-3842-25	38,0	+0,050 +0,150	42,0	25,0
GSM-4044-10	40,0	+0,050 +0,150	44,0	10,0
GSM-4044-16	40,0	+0,050 +0,150	44,0	16,5
GSM-4044-20	40,0	+0,050 +0,150	44,0	20,0
GSM-4044-30	40,0	+0,050 +0,150	44,0	30,0
GSM-4044-40	40,0	+0,050 +0,150	44,0	40,0
GSM-4044-50	40,0	+0,050 +0,150	44,0	50,0
GSM-4044-525	40,0	+0,050 +0,150	44,0	52,5
GSM-4246-40	42,0	+0,050 +0,150	46,0	40,0
GSM-4448-20	44,0	+0,050 +0,150	48,0	20,0
GSM-4550-22	45,0	+0,050 +0,150	50,0	22,0
GSM-4550-235	45,0	+0,050 +0,150	50,0	23,5
GSM-4550-30	45,0	+0,050 +0,150	50,0	30,0
GSM-4550-38	45,0	+0,050 +0,150	50,0	38,0
GSM-4550-40	45,0	+0,050 +0,150	50,0	40,0
GSM-4550-50	45,0	+0,050 +0,150	50,0	50,0
GSM-5055-20	50,0	+0,050 +0,150	55,0	20,0
GSM-5055-25	50,0	+0,050 +0,150	55,0	25,0
GSM-5055-30	50,0	+0,050 +0,150	55,0	30,0
GSM-5055-40	50,0	+0,050 +0,150	55,0	40,0
GSM-5055-50	50,0	+0,050 +0,150	55,0	50,0
GSM-5257-20	52,0	+0,060 +0,180	57,0	20,0

Bestellnummer	d1	d1-Toleranz*	d2	b1 h13
GSM-5560-20	55,0	+0,060 +0,180	60,0	20,0
GSM-5560-40	55,0	+0,060 +0,180	60,0	40,0
GSM-5560-50	55,0	+0,060 +0,180	60,0	50,0
GSM-5560-60	55,0	+0,060 +0,180	60,0	60,0
GSM-6065-30	60,0	+0,060 +0,180	65,0	30,0
GSM-6065-40	60,0	+0,060 +0,180	65,0	40,0
GSM-6065-50	60,0	+0,060 +0,180	65,0	50,0
GSM-6065-60	60,0	+0,060 +0,180	65,0	60,0
GSM-6065-70	60,0	+0,060 +0,180	65,0	70,0
GSM-6267-35	62,0	+0,100 +0,250	67,0	35,0
GSM-6267-72	62,0	+0,060 +0,180	67,0	72,0
GSM-6570-104	65,0	+0,060 +0,180	70,0	104,0
GSM-6570-30	65,0	+0,060 +0,180	70,0	30,0
GSM-6570-50	65,0	+0,060 +0,180	70,0	50,0
GSM-6873-60	68,0	+0,060 +0,180	73,0	60,0
GSM-7075-60	70,0	+0,060 +0,180	75,0	60,0
GSM-7277-245	72,0	+0,060 +0,180	77,0	24,5
GSM-7277-76	72,0	+0,060 +0,180	77,0	76,0
GSM-7580-40	75,0	+0,060 +0,180	80,0	40,0
GSM-7580-60	75,0	+0,060 +0,180	80,0	60,0
GSM-8085-60	80,0	+0,060 +0,180	85,0	60,0
GSM-8085-100	80,0	+0,060 +0,180	85,0	100,0
GSM-8590-100	85,0	+0,072 +0,212	90,0	100,0
GSM-9095-100	90,0	+0,072 +0,212	95,0	100,0
GSM-95100-100	95,0	+0,072 +0,212	100,0	100,0
GSM-100105-215	100,0	+0,072 +0,212	105,0	21,5
GSM-100105-30	100,0	+0,072 +0,212	105,0	30,0
GSM-100105-32	100,0	+0,072 +0,212	105,0	32,0
GSM-100105-100	100,0	+0,072 +0,212	105,0	100,0
GSM-110115-100	110,0	+0,072 +0,212	115,0	100,0
GSM-120125-100	120,0	+0,072 +0,212	125,0	100,0
GSM-125130-100	125,0	+0,085 +0,245	130,0	100,0
GSM-130135-100	130,0	+0,085 +0,245	135,0	100,0
GSM-135140-80	135,0	+0,085 +0,245	140,0	80,0
GSM-140145-100	140,0	+0,085 +0,245	145,0	100,0
GSM-140145-104	140,0	+0,085 +0,245	145,0	104,0
GSM-150155-100	150,0	+0,085 +0,245	155,0	100,0

* nach dem Einpressen; Messverfahren ► Seite 59



Noch mehr Abmessungen ab Lager

Über 300 weitere Abmessungen stehen jetzt zur Verfügung. Sie können online nach Ihrem Wunschlager suchen.

► www.igus.de/iglidur-sonderabmessungen

iglidur® G | Lieferprogramm

Gleitlager mit Bund

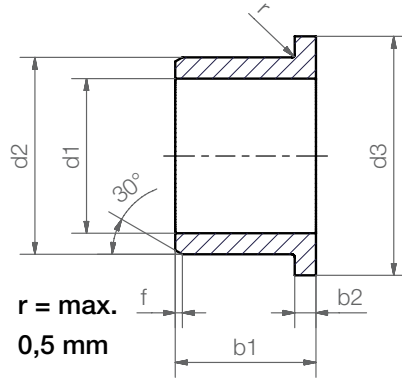

Bestellschlüssel

GFM-0304-02



- Gesamtlänge b1
- Außendurchmesser d2
- Innendurchmesser d1
- metrisch
- mit Bund (Form F)
- Werkstoff iglidur® G

Abmessungen nach ISO 3547-1 und Sonderabmessungen

Fase in Abhängigkeit von d1

d1 [mm]:	Ø 1-6	Ø 6-12	Ø 12-30	Ø > 30
f [mm]:	0,3	0,5	0,8	1,2

Abmessungen [mm]

Bestellnummer	d1	d1-Toleranz*	d2	d3	b1	b2
					h13	-0,14
GFM-03040-15	3,0	+0,010 +0,040	4,0	7,5	15,0	0,5
GFM-0304-02	3,0	+0,014 +0,054	4,5	7,5	2,0	0,5
GFM-0304-0275	3,0	+0,014 +0,054	4,5	7,5	2,7	0,75
GFM-0304-03	3,0	+0,014 +0,054	4,5	7,5	3,0	0,75
GFM-0304-05	3,0	+0,014 +0,054	4,5	7,5	5,0	0,75
GFM-0304-15	3,0	+0,014 +0,054	4,5	7,5	15,0	0,75
GFM-030407-05	3,0	+0,014 +0,054	4,5	7,0	5,0	0,75
GFM-0405-03	4,0	+0,020 +0,068	5,5	9,5	3,0	0,75
GFM-0405-04	4,0	+0,020 +0,068	5,5	9,5	4,0	0,75
GFM-0405-06	4,0	+0,020 +0,068	5,5	9,5	6,0	0,75
GFM-0405-0255	4,0	+0,020 +0,068	5,5	9,5	2,5	0,75
GFM-04050-04	4,0	+0,010 +0,040	5,0	9,5	4,0	0,5
GFM-04050-06	4,0	+0,010 +0,040	5,0	9,5	6,0	0,5
GFM-040508-10	4,0	+0,020 +0,068	5,5	8,0	10,0	1,0
GFM-0506-035	5,0	+0,010 +0,040	6,0	10,0	3,5	0,5
GFM-0506-04	5,0	+0,010 +0,040	6,0	10,0	4,0	0,5
GFM-0506-05	5,0	+0,010 +0,040	6,0	10,0	5,0	0,5
GFM-0506-06	5,0	+0,010 +0,040	6,0	10,0	6,0	0,5
GFM-0506-15	5,0	+0,010 +0,040	6,0	10,0	15,3	0,5
GFM-0507-03	5,0	+0,020 +0,068	7,0	11,0	3,5	1,0
GFM-0507-04	5,0	+0,020 +0,068	7,0	11,0	4,0	1,0
GFM-0507-05	5,0	+0,020 +0,068	7,0	11,0	5,0	1,0
GFM-0507-07	5,0	+0,020 +0,068	7,0	11,0	7,0	1,0
GFM-0507-11	5,0	+0,020 +0,068	7,0	11,0	11,0	1,0
GFM-0507-145	5,0	+0,020 +0,068	7,0	11,0	14,5	1,0

* nach dem Einpressen; Messverfahren ► Seite 59



Lieferzeit ab Lager



Preise Online-Preisliste
www.igus.de/de/g



Gleitlager mit Bund

Abmessungen [mm]

Bestellnummer	d1	d1-Toleranz*	d2	d3 d13	b1 h13	b2 -0,14
GFM-0507-30	5,0	+0,020 +0,068	7,0	11,0	5,0	1,0
GFM-050709-05	5,0	+0,020 +0,068	7,0	9,5	5,0	1,0
GFM-050715-04	5,0	+0,020 +0,068	7,0	15,0	4,0	1,0
GFM-0607-024	6,0	+0,010 +0,040	7,0	11,0	2,4	0,5
GFM-0607-029	6,0	+0,010 +0,040	7,0	11,0	2,9	0,5
GFM-0607-045	6,0	+0,010 +0,040	7,0	11,0	4,5	0,5
GFM-0607-055	6,0	+0,010 +0,040	7,0	11,0	5,5	0,5
GFM-0607-06	6,0	+0,010 +0,040	7,0	11,0	6,0	0,5
GFM-0607-08	6,0	+0,010 +0,040	7,0	11,0	8,0	0,5
GFM-0607-10	6,0	+0,010 +0,040	7,0	11,0	10,0	0,5
GFM-060709-045	6,0	+0,010 +0,040	7,0	9,0	4,5	0,5
GFM-060709-10	6,0	+0,010 +0,040	7,0	9,0	10,0	0,5
GFM-0608-025	6,0	+0,020 +0,068	8,0	12,0	2,5	1,0
GFM-0608-04	6,0	+0,020 +0,068	8,0	12,0	4,0	1,0
GFM-0608-048	6,0	+0,020 +0,068	8,0	12,0	4,8	1,0
GFM-0608-05	6,0	+0,020 +0,068	8,0	12,0	5,0	1,0
GFM-0608-06	6,0	+0,020 +0,068	8,0	12,0	6,0	1,0
GFM-0608-07	6,0	+0,020 +0,068	8,0	12,0	7,0	1,0
GFM-0608-08	6,0	+0,020 +0,068	8,0	12,0	8,0	1,0
GFM-0608-10	6,0	+0,020 +0,068	8,0	12,0	10,0	1,0
GFM-0608-25	6,0	+0,020 +0,068	8,0	12,0	25,0	1,0
GFM-0608-35	6,0	+0,020 +0,068	8,0	12,0	35,0	1,0
GFM-060810-08	6,0	+0,020 +0,068	8,0	10,0	8,0	1,0
GFM-060814-028	6,0	+0,020 +0,068	8,0	14,0	2,8	1,0
GFM-060814-12	6,0	+0,020 +0,068	8,0	14,0	12,0	1,0
GFM-0708-017	7,0	+0,013 +0,049	8,0	12,0	1,7	0,5
GFM-0708-03	7,0	+0,013 +0,049	8,0	12,0	3,0	0,5
GFM-0708-08	7,0	+0,013 +0,049	8,0	12,0	8,0	0,5
GFM-0709-06	7,0	+0,025 +0,083	9,0	15,0	6,0	1,0
GFM-0709-10	7,0	+0,025 +0,083	9,0	15,0	10,0	1,0
GFM-0709-12	7,0	+0,025 +0,083	9,0	15,0	12,0	1,0
GFM-0709-035	7,0	+0,025 +0,083	9,0	15,0	3,5	1,0
GFM-070919-10	7,0	+0,025 +0,083	9,0	19,0	10,0	1,0
GFM-0809-03	8,0	+0,013 +0,049	9,0	15,0	3,0	0,5
GFM-0809-035	8,0	+0,013 +0,049	9,0	13,0	3,5	0,5
GFM-0809-055	8,0	+0,013 +0,049	9,0	13,0	5,5	0,5
GFM-0809-08	8,0	+0,013 +0,049	9,0	13,0	8,0	0,5
GFM-0809-12	8,0	+0,013 +0,049	9,0	13,0	12,0	0,5
GFM-0810-03	8,0	+0,025 +0,083	10,0	15,0	3,0	1,0
GFM-0810-11	8,0	+0,025 +0,083	10,0	14,0	11,0	1,0
GFM-0810-035	8,0	+0,025 +0,083	10,0	15,0	3,5	1,0
GFM-0810-04	8,0	+0,025 +0,083	10,0	15,0	4,0	1,0

* nach dem Einpressen; Messverfahren ► Seite 59

Abmessungen [mm]

Bestellnummer	d1	d1-Toleranz*	d2	d3 d13	b1 h13	b2 -0,14
GFM-0810-050	8,0	+0,025 +0,083	10,0	15,0	5,0	1,0
GFM-0810-05	8,0	+0,025 +0,083	10,0	15,0	5,5	1,0
GFM-0810-065	8,0	+0,025 +0,083	10,0	15,0	6,5	1,0
GFM-0810-07	8,0	+0,025 +0,083	10,0	15,0	7,5	1,0
GFM-0810-09	8,0	+0,025 +0,083	10,0	15,0	9,5	1,0
GFM-0810-10	8,0	+0,025 +0,083	10,0	14,0	10,0	1,0
GFM-0810-15	8,0	+0,025 +0,083	10,0	15,0	15,0	1,0
GFM-0810-25	8,0	+0,025 +0,083	10,0	15,0	25,0	1,0
GFM-0810-30	8,0	+0,025 +0,083	10,0	15,0	30,0	1,0
GFM-081012-125	8,0	+0,025 +0,083	10,0	12,0	12,5	1,0
GFM-081013-08	8,0	+0,025 +0,083	10,0	13,0	8,0	1,0
GFM-081014-05	8,0	+0,040 +0,098	10,0	14,0	5,0	1,0
GFM-081014-06	8,0	+0,025 +0,083	10,0	14,0	6,0	1,0
GFM-081014-08	8,0	+0,025 +0,083	10,0	14,0	8,0	1,0
GFM-081014-10	8,0	+0,040 +0,098	10,0	14,0	10,0	1,0
GFM-081016-11	8,0	+0,025 +0,083	10,0	16,0	11,5	1,5
GFM-081016-15	8,0	+0,025 +0,083	10,0	16,0	15,5	1,5
GFM-081017-15	8,0	+0,025 +0,083	10,0	17,0	15,0	1,0
GFM-081018-03	8,0	+0,025 +0,083	10,0	18,0	3,0	1,0
GFM-0812-06	8,0	+0,040 +0,130	12,0	16,0	6,0	2,0
GFM-081221-08	8,0	+0,040 +0,130	12,0	21,0	8,0	2,0
GFM-0910-065	9,0	+0,013 +0,049	10,0	15,0	6,5	0,5
GFM-0910-17	9,0	+0,013 +0,049	10,0	15,0	17,5	0,5
GFM-1011-03	10,0	+0,013 +0,046	11,0	20,0	3,5	0,5
GFM-1011-044	10,0	+0,013 +0,049	11,0	15,0	4,4	0,5
GFM-1011-10	10,0	+0,013 +0,049	11,0	15,0	10,0	0,5
GFM-1012-035	10,0	+0,025 +0,083	12,0	18,0	3,5	1,0
GFM-1012-04	10,0	+0,025 +0,083	12,0	18,0	4,0	1,0
GFM-1012-05	10,0	+0,025 +0,083	12,0	18,0	5,0	1,0
GFM-1012-06	10,0	+0,025 +0,083	12,0	18,0	6,0	1,0
GFM-1012-07	10,0	+0,025 +0,083	12,0	18,0	7,0	1,0
GFM-1012-09	10,0	+0,025 +0,083	12,0	18,0	9,0	1,0
GFM-1012-10	10,0	+0,025 +0,083	12,0	18,0	10,0	1,0
GFM-1012-12	10,0	+0,025 +0,083	12,0	18,0	12,0	1,0
GFM-1012-15	10,0	+0,025 +0,083	12,0	18,0	15,0	1,0
GFM-1012-17	10,0	+0,025 +0,083	12,0	18,0	17,0	1,0
GFM-101214-07	10,0	+0,025 +0,083	12,0	14,0	7,0	1,0
GFM-101215-12	10,0	+0,025 +0,083	12,0	15,0	12,0	1,0
GFM-101216-06	10,0	+0,025 +0,083	12,0	16,0	6,0	1,0
GFM-101216-09	10,0	+0,025 +0,083	12,0	16,0	9,0	1,0
GFM-101216-15	10,0	+0,025 +0,083	12,0	16,0	15,0	1,0
GFM-1112-06	11,0	+0,016 +0,059	12,0	16,0	6,0	0,5

* nach dem Einpressen; Messverfahren ► Seite 59

Lieferzeit ab Lager

Preise Online-Preisliste
www.igus.de/de/g



Gleitlager mit Bund

Abmessungen [mm]

Bestellnummer	d1	d1-Toleranz*	d2	d3 d13	b1 h13	b2 -0,14
GFM-1213-03	12,0	+0,016 +0,059	13,0	17,0	3,0	0,5
GFM-121315-12	12,0	+0,016 +0,059	13,0	15,0	12,0	0,5
GFM-1213-12	12,0	+0,016 +0,059	13,0	17,0	12,0	0,5
GFM-1214-03	12,0	+0,032 +0,102	14,0	20,0	3,0	1,0
GFM-1214-05	12,0	+0,032 +0,102	14,0	20,0	5,0	1,0
GFM-1214-06	12,0	+0,032 +0,102	14,0	20,0	6,0	1,0
GFM-1214-07	12,0	+0,032 +0,102	14,0	20,0	7,0	1,0
GFM-1214-09	12,0	+0,032 +0,102	14,0	20,0	9,0	1,0
GFM-1214-10	12,0	+0,032 +0,102	14,0	20,0	10,0	1,0
GFM-1214-11	12,0	+0,032 +0,102	14,0	20,0	11,0	1,0
GFM-1214-12	12,0	+0,032 +0,102	14,0	20,0	12,0	1,0
GFM-1214-15	12,0	+0,032 +0,102	14,0	20,0	15,0	1,0
GFM-1214-17	12,0	+0,032 +0,102	14,0	20,0	17,0	1,0
GFM-1214-20	12,0	+0,032 +0,102	14,0	20,0	20,0	1,0
GFM-1214-24	12,0	+0,032 +0,102	14,0	20,0	24,0	1,0
GFM-1214-31	12,0	+0,032 +0,102	14,0	20,0	31,0	1,0
GFM-1214-40	12,0	+0,032 +0,102	14,0	20,0	40,0	1,0
GFM-121418-04	12,0	+0,032 +0,102	14,0	18,0	4,0	1,0
GFM-121418-08	12,0	+0,032 +0,102	14,0	18,0	8,0	1,0
GFM-121418-10	12,0	+0,032 +0,102	14,0	18,0	10,0	1,0
GFM-121418-12	12,0	+0,032 +0,102	14,0	18,0	12,0	1,0
GFM-121418-15	12,0	+0,032 +0,102	14,0	18,0	15,0	1,0
GFM-121418-20	12,0	+0,032 +0,102	14,0	18,0	20,0	1,0
GFM-1315-06	13,0	+0,032 +0,102	15,0	22,0	6,0	1,0
GFM-1315-08	13,0	+0,032 +0,102	15,0	22,0	8,0	1,0
GFM-1416-03	14,0	+0,032 +0,102	16,0	22,0	3,0	1,0
GFM-1416-04	14,0	+0,032 +0,102	16,0	22,0	4,0	1,0
GFM-1416-06	14,0	+0,032 +0,102	16,0	22,0	6,0	1,0
GFM-1416-08	14,0	+0,032 +0,102	16,0	22,0	8,0	1,0
GFM-1416-10	14,0	+0,032 +0,102	16,0	22,0	10,0	1,0
GFM-1416-12	14,0	+0,032 +0,102	16,0	22,0	12,0	1,0
GFM-1416-17	14,0	+0,032 +0,102	16,0	22,0	17,0	1,0
GFM-1416-21	14,0	+0,032 +0,102	16,0	22,0	21,0	1,0
GFM-1516-02	15,0	+0,016 +0,059	16,0	20,0	2,0	0,5
GFM-1516-025	15,0	+0,016 +0,059	16,0	20,0	2,5	0,5
GFM-1516-03	15,0	+0,016 +0,059	16,0	20,0	3,0	0,5
GFM-1516-15	15,0	+0,016 +0,059	16,0	20,0	15,0	0,5
GFM-1517-04	15,0	+0,032 +0,102	17,0	23,0	4,0	1,0
GFM-1517-045	15,0	+0,032 +0,102	17,0	23,0	4,5	1,0
GFM-1517-05	15,0	+0,032 +0,102	17,0	23,0	5,0	1,0
GFM-1517-09	15,0	+0,032 +0,102	17,0	23,0	9,0	1,0
GFM-1517-12	15,0	+0,032 +0,102	17,0	23,0	12,0	1,0

* nach dem Einpressen; Messverfahren ► Seite 59

Abmessungen [mm]

Bestellnummer	d1	d1-Toleranz*	d2	d3 d13	b1 h13	b2 -0,14
GFM-1517-17	15,0	+0,032 +0,102	17,0	23,0	17,0	1,0
GFM-1517-20	15,0	+0,032 +0,102	17,0	23,0	20,0	1,0
GFM-151824-32	15,0	+0,032 +0,102	18,0	24,0	32,0	1,5
GFM-1618-04	16,0	+0,032 +0,102	18,0	24,0	4,0	1,0
GFM-1618-05	16,0	+0,032 +0,102	18,0	24,0	5,0	1,0
GFM-1618-06	16,0	+0,032 +0,102	18,0	24,0	6,0	1,0
GFM-1618-09	16,0	+0,032 +0,102	18,0	24,0	9,0	1,0
GFM-1618-12	16,0	+0,032 +0,102	18,0	24,0	12,0	1,0
GFM-1618-16	16,0	+0,032 +0,102	18,0	24,0	16,0	1,0
GFM-1618-17	16,0	+0,032 +0,102	18,0	24,0	17,0	1,0
GFM-1618-21	16,0	+0,032 +0,102	18,0	24,0	21,0	1,0
GFM-1719-09	17,0	+0,032 +0,102	19,0	25,0	9,0	1,0
GFM-1719-25	17,0	+0,032 +0,102	19,0	25,0	25,0	1,0
GFM-1820-04	18,0	+0,032 +0,102	20,0	26,0	4,0	1,0
GFM-1820-06	18,0	+0,032 +0,102	20,0	26,0	6,0	1,0
GFM-1820-09	18,0	+0,032 +0,102	20,0	26,0	9,0	1,0
GFM-1820-11	18,0	+0,032 +0,102	20,0	26,0	11,0	1,0
GFM-1820-12	18,0	+0,032 +0,102	20,0	26,0	12,0	1,0
GFM-1820-17	18,0	+0,032 +0,102	20,0	26,0	17,0	1,0
GFM-1820-22	18,0	+0,032 +0,102	20,0	26,0	22,0	1,0
GFM-1820-30	18,0	+0,032 +0,102	20,0	26,0	30,0	1,0
GFM-1820-32	18,0	+0,032 +0,102	20,0	26,0	32,0	1,0
GFM-182022-06	18,0	+0,032 +0,102	20,0	22,0	6,0	1,0
GFM-1822-28	18,0	+0,032 +0,102	22,0	26,0	28,0	2,0
GFM-2021-035	20,0	+0,020 +0,072	21,0	26,0	3,5	0,5
GFM-2021-15	20,0	+0,020 +0,072	21,0	25,0	15,0	0,5
GFM-2021-20	20,0	+0,020 +0,072	21,0	25,0	20,0	0,5
GFM-2023-07	20,0	+0,040 +0,124	23,0	30,0	7,0	1,5
GFM-2023-11	20,0	+0,040 +0,124	23,0	30,0	11,5	1,5
GFM-2023-16	20,0	+0,040 +0,124	23,0	30,0	16,5	1,5
GFM-2023-21	20,0	+0,040 +0,124	23,0	30,0	21,5	1,5
GFM-202326-07	20,0	+0,040 +0,124	23,0	26,0	7,0	1,5
GFM-202326-21	20,0	+0,040 +0,124	23,0	26,0	21,5	1,5
GFM-202328-15	20,0	+0,040 +0,124	23,0	28,0	15,0	1,5
GFM-202329-20	20,0	+0,040 +0,124	23,0	29,0	20,0	1,5
GFM-2224-25	22,0	+0,040 +0,124	24,0	30,0	25,0	1,0
GFM-222529-045	22,0	+0,040 +0,124	25,0	29,0	4,5	1,5
GFM-222535-315	22,0	+0,040 +0,124	25,0	35,0	31,5	1,5
GFM-2427-07	24,0	+0,040 +0,124	27,0	32,0	7,0	1,5
GFM-2427-10	24,0	+0,040 +0,124	27,0	32,0	10,0	1,5
GFM-2526-25	25,0	+0,020 +0,072	26,0	30,0	25,0	0,5
GFM-2527-07	25,0	+0,040 +0,124	27,0	32,0	7,0	1,0

* nach dem Einpressen; Messverfahren ► Seite 59

Lieferzeit ab Lager

Preise Online-Preisliste
www.igus.de/de/g



Gleitlager mit Bund

Abmessungen [mm]

Bestellnummer	d1	d1-Toleranz*	d2	d3 d13	b1 h13	b2 -0,14
GFM-2527-48	25,0	+0,040 +0,124	27,0	32,0	48,0	1,0
GFM-252830-10	25,0	+0,040 +0,124	28,0	30,0	10,0	1,5
GFM-2528-11	25,0	+0,040 +0,124	28,0	35,0	11,5	1,5
GFM-2528-16	25,0	+0,040 +0,124	28,0	35,0	16,5	1,5
GFM-2528-21	25,0	+0,040 +0,124	28,0	35,0	21,5	1,5
GFM-2630-12	26,0	+0,040 +0,124	30,0	37,0	12,0	2,0
GFM-2730-20	27,0	+0,040 +0,124	30,0	38,0	20,0	1,5
GFM-2830-10	28,0	+0,040 +0,124	30,0	36,0	10,0	1,0
GFM-2830-36	28,0	+0,040 +0,124	30,0	35,0	36,0	1,0
GFM-2830-48	28,0	+0,040 +0,124	30,0	35,0	48,0	1,0
GFM-283036-31	28,0	+0,040 +0,124	30,0	36,0	31,0	1,0
GFM-283239-20	28,0	+0,040 +0,124	32,0	39,0	20,0	2,0
GFM-283250-35	28,0	+0,040 +0,124	32,0	50,0	35,0	2,0
GFM-3031-20	30,0	+0,040 +0,124	31,0	36,0	20,0	0,5
GFM-3031-30	30,0	+0,040 +0,124	31,0	35,0	30,0	0,5
GFM-3032-04	30,0	+0,040 +0,124	32,0	37,0	4,0	1,0
GFM-3032-12	30,0	+0,040 +0,124	32,0	37,0	12,0	1,0
GFM-3032-17	30,0	+0,040 +0,124	32,0	37,0	17,5	1,0
GFM-3032-22	30,0	+0,040 +0,124	32,0	37,0	22,0	1,0
GFM-3034-09	30,0	+0,040 +0,124	34,0	42,0	9,0	2,0
GFM-3034-16	30,0	+0,040 +0,124	34,0	42,0	16,0	2,0
GFM-3034-20	30,0	+0,040 +0,124	34,0	42,0	20,0	2,0
GFM-3034-26	30,0	+0,040 +0,124	34,0	42,0	26,0	2,0
GFM-3034-37	30,0	+0,040 +0,124	34,0	42,0	37,0	2,0
GFM-303440-10	30,0	+0,040 +0,124	34,0	40,0	10,0	2,0
GFM-3236-16	32,0	+0,050 +0,150	36,0	40,0	16,0	2,0
GFM-3236-26	32,0	+0,050 +0,150	36,0	40,0	26,0	2,0
GFM-343850-35	34,0	+0,050 +0,150	38,0	50,0	35,0	2,0
GFM-3539-058	35,0	+0,050 +0,150	39,0	47,0	5,8	2,0
GFM-3539-07	35,0	+0,050 +0,150	39,0	47,0	7,0	2,0
GFM-3539-12	35,0	+0,050 +0,150	39,0	47,0	12,0	2,0
GFM-3539-16	35,0	+0,050 +0,150	39,0	47,0	16,0	2,0
GFM-3539-26	35,0	+0,050 +0,150	39,0	47,0	26,0	2,0
GFM-3539-36	35,0	+0,050 +0,150	39,0	47,0	36,0	2,0
GFM-3842-22	38,0	+0,050 +0,150	42,0	54,0	22,0	2,0
GFM-4044-07	40,0	+0,050 +0,150	44,0	52,0	7,0	2,0
GFM-4044-14	40,0	+0,050 +0,150	44,0	52,0	14,0	2,0
GFM-4044-20	40,0	+0,050 +0,150	44,0	52,0	20,0	2,0
GFM-4044-30	40,0	+0,050 +0,150	44,0	52,0	30,0	2,0
GFM-4044-40	40,0	+0,050 +0,150	44,0	52,0	40,0	2,0
GFM-4044-50	40,0	+0,050 +0,150	44,0	52,0	50,0	2,0
GFM-4046-20	40,0	+0,050 +0,150	46,0	50,0	20,0	2,0

* nach dem Einpressen; Messverfahren ► Seite 59



Gleitlager mit Bund

Abmessungen [mm]

Bestellnummer	d1	d1-Toleranz*	d2	d3 d13	b1 h13	b2 -0,14
GFM-4246-19	42,0	+0,050 +0,150	46,0	53,0	19,0	2,0
GFM-4550-25	45,0	+0,050 +0,150	50,0	58,0	25,0	2,0
GFM-4550-30	45,0	+0,050 +0,150	50,0	58,0	30,0	2,0
GFM-4550-50	45,0	+0,050 +0,150	50,0	58,0	50,0	2,0
GFM-5055-07	50,0	+0,050 +0,150	55,0	63,0	7,0	2,0
GFM-5055-10	50,0	+0,050 +0,150	55,0	63,0	10,0	2,0
GFM-5055-25	50,0	+0,050 +0,150	55,0	63,0	25,0	2,0
GFM-5055-40	50,0	+0,050 +0,150	55,0	63,0	40,0	2,0
GFM-5055-50	50,0	+0,050 +0,150	55,0	63,0	50,0	2,0
GFM-6065-07	60,0	+0,060 +0,180	65,0	73,0	7,0	2,0
GFM-6065-22	60,0	+0,060 +0,180	65,0	73,0	22,0	2,0
GFM-6065-30	60,0	+0,060 +0,180	65,0	73,0	30,0	2,0
GFM-6065-50	60,0	+0,060 +0,180	65,0	73,0	50,0	2,0
GFM-606580-62	60,0	+0,060 +0,180	65,0	80,0	62,0	2,0
GFM-6570-50	65,0	+0,060 +0,180	70,0	78,0	50,0	2,0
GFM-7075-50	70,0	+0,060 +0,180	75,0	83,0	50,0	2,0
GFM-7580-50	75,0	+0,060 +0,180	80,0	88,0	50,0	2,0
GFM-8085-50	80,0	+0,060 +0,180	85,0	93,0	50,0	2,5
GFM-8085-100	80,0	+0,060 +0,180	85,0	93,0	100,0	2,5
GFM-8590-100	85,0	+0,072 +0,212	90,0	98,0	100,0	2,5
GFM-9095-100	90,0	+0,072 +0,212	95,0	103,0	100,0	2,5
GFM-95100-100	95,0	+0,072 +0,212	100,0	108,0	100,0	2,5
GFM-100105-425	100,0	+0,072 +0,212	105,0	113,0	42,5	2,5
GFM-100105-100	100,0	+0,072 +0,212	105,0	113,0	100,0	2,5
GFM-110115-100	110,0	+0,072 +0,212	115,0	123,0	100,0	2,5
GFM-120125-80	120,0	+0,072 +0,212	125,0	133,0	80,0	2,5
GFM-120125-100	120,0	+0,072 +0,212	125,0	133,0	100,0	2,5
GFM-125130-100	125,0	+0,085 +0,245	130,0	138,0	100,0	2,5
GFM-130135-100	130,0	+0,085 +0,245	135,0	143,0	100,0	2,5
GFM-140145-100	140,0	+0,085 +0,245	145,0	153,0	100,0	2,5
GFM-150155-40	150,0	+0,085 +0,245	155,0	163,0	40,0	2,5
GFM-150155-100	150,0	+0,085 +0,245	155,0	163,0	100,0	2,5
GFM-195205240-65	195,0	+0,100 +0,285	205,0	240,0	65,0	5,0

* nach dem Einpressen; Messverfahren ► Seite 59



Sie finden ihre Abmessung nicht?

Benötigen sie eine andere Länge, Abmessung oder Toleranz? Sie suchen eine bestimmte Form oder Alternative für ihre Anwendung? Bitte rufen sie uns an. igus® prüft genau ihre Anforderung und bietet ihnen kurzfristig eine Lösung an.



Lieferzeit ab Lager



Preise Online-Preisliste

www.igus.de/de/g

Anlaufscheiben

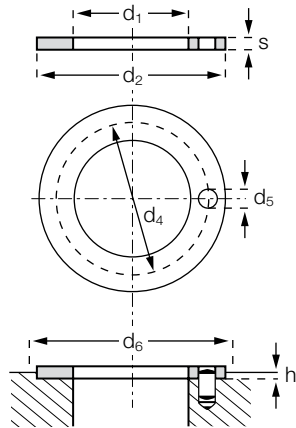

Bestellschlüssel

GTM-0509-006



- Höhe s
- Außendurchmesser d2
- Innendurchmesser d1
- metrisch
- Anlaufscheibe (Form T)
- Werkstoff iglidur® G

Abmessungen nach ISO 3547-1 und Sonderabmessungen

Abmessungen [mm]

Bestellnummer	d1 +0,25	d2 -0,25	s -0,05	d4 -0,12 +0,12	d5 +0,375 +0,125	h +0,2 -0,2	d6 +0,12
GTM-0408-005	4,0	8,0	0,5	**	**	0,2	
GTM-0409-006	4,0	9,0	0,6	**	**	0,3	
GTM-0410-005	4,0	10,0	0,5	**	**	0,2	
GTM-0411-005	4,0	11,0	0,5 (-0,06)	**	**	0,2	
GTM-0509-006	5,0	9,5	0,6	**	**	0,3	9,5
GTM-0611-010	6,0	11,0	1,0	**	**	0,7	
GTM-0612-015	6,0	12,0	1,5	**	**	1,0	
GTM-0615-015	6,0	15,0	1,5	**	**	1,0	15
GTM-0620-015	6,0	20,0	1,5	13,0	1,5	1,0	20
GTM-0712-005	7,0	12,0	0,5	**	**	0,2	
GTM-0713-005	7,0	13,0	0,5	**	**	0,2	13
GTM-0815-005	8,0	15,0	0,5	**	**	0,2	15
GTM-0815-015	8,0	15,0	1,5	**	**	1,0	15
GTM-0818-010	8,0	18,0	1,0	**	**	0,7	18
GTM-0818-015	8,0	18,0	1,5	13,0	1,5	1,0	18
GTM-0818-020	8,0	18,0	2,0	**	**	1,5	
GTM-0913-010	9,0	13,0	1,0	**	**	0,7	
GTM-0918-015	9,0	18,0	1,5	13,5	1,5	1,0	18
GTM-1018-005	10,0	17,8	0,5	**	**	0,2	
GTM-1018-010	10,0	18,0	1,0	**	**	0,7	18
GTM-1018-015	10,0	18,0	1,5	**	**	1,0	
GTM-1018-020	10,0	18,0	2,0	**	**	1,5	18
GTM-1020-015	10,0	20,0	1,5	**	**	0,7	
GTM-1115-010	11,0	15,0	1,0	**	**	0,7	

** Ausführung ohne Fixierbohrung



Lieferzeit ab Lager



Preise Online-Preisliste
www.igus.de/de/g



Abmessungen [mm]

Bestellnummer	d1	d2	s	d4	d5	h	d6
	+0,25	-0,25	-0,05	-0,12 +0,12	+0,375 +0,125	+0,2 -0,2	+0,12
GTM-1127-005	11,0	27,0	0,5	**	**	0,2	
GTM-1224-015	12,0	24,0	1,5	18,0	1,5	1,0	24
GTM-1230-015	12,0	30,0	1,5	**	**	1,0	
GTM-1420-015	14,0	20,0	1,5	**	**	1,0	20
GTM-1426-015	14,0	26,0	1,5	20,0	2,0	1,0	26
GTM-1522-008	15,0	22,0	0,8	**	**	0,5	22
GTM-1519-008	15,0	19,0	0,8	**	**	0,5	
GTM-1524-015	15,0	24,0	1,5	19,5	1,5	1,0	24
GTM-1524-0275	15,0	24,0	2,75	**	**	2,0	24
GTM-1628-010	16,0	28,0	1,0	**	**	0,7	
GTM-1630-015	16,0	30,0	1,5	22,0	2,0	1,0	30
GTM-1832-015	18,0	32,0	1,5	25,0	2,0	1,0	32
GTM-2036-015	20,0	36,0	1,5	28,0	3,0	1,0	36
GTM-2230-015	22,0	30,0	1,5	**	**	1,0	
GTM-2238-015	22,0	38,0	1,5	30,0	3,0	1,0	38
GTM-2442-015	24,0	42,0	1,5	33,0	3,0	1,0	42
GTM-2644-015	26,0	44,0	1,5	35,0	3,0	1,0	44
GTM-2835-005	28,5	35,8	0,5	**	**	0,2	35,8
GTM-2848-015	28,0	48,0	1,5	38,0	4,0	1,0	48
GTM-3246-010	32,0	45,8	1,0	**	**	0,7	
GTM-3254-015	32,0	54,0	1,5	43,0	4,0	1,0	54
GTM-3862-015	38,0	62,0	1,5	50,0	4,0	1,0	62
GTM-4266-015	42,0	66,0	1,5	54,0	4,0	1,0	66
GTM-4874-020	48,0	74,0	2,0	61,0	4,0	1,5	74
GTM-52569-020	52,5	69,0	2,0	**	**	1,5	
GTM-5278-020	52,0	78,0	2,0	65,0	4,0	1,5	78
GTM-6278-020	62,0	78,0	2,0	**	**	1,5	
GTM-6290-010	62,0	90,0	1,0	**	**	0,7	
GTM-6290-020	62,0	90,0	2,0	76,0	4,0	1,5	90
GTM-6881-020	68,0	81,0	2,0	**	**	1,5	81
GTM-78114-015	78,0	114,0	1,5	**	**	1,0	
GTM-80114-015	80,5	114,0	1,5	**	**	1,0	

** Ausführung ohne Fixierbohrung



Noch mehr Abmessungen ab Lager

Über 300 weitere Abmessungen stehen jetzt zur Verfügung. Sie können online nach Ihrem Wunschlager suchen.

► www.igus.de/iglidur-sonderabmessungen

zylindrische Gleitlager

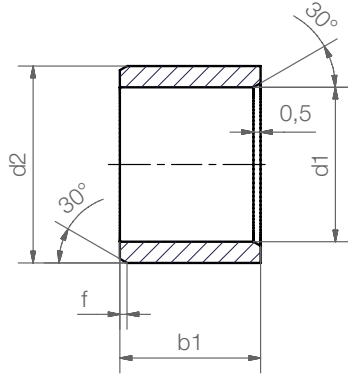

Bestellschlüssel

GSI-0203-03



- Gesamtlänge b1
- Außendurchmesser d2
- Innendurchmesser d1
- Inch
- zylindrisch (Form S)
- Werkstoff iglidur® G

Fase in Abhängigkeit von d1

d1 [Inch]:	Ø 0,040–0,236	Ø 0,236–0,472	Ø 0,472–1,18	Ø > 1,18
f [Inch]:	0,012	0,019	0,031	0,047

Abmessungen [Inch]

Bestellnummer	d1	d2	b1	d1*		Einpressbohrung		Wellenmaße	
				max.	min.	max.	min.	max.	min.
GSI-0203-03	1/8	3/16	3/16	,1269	,1251	,1878	,1873	,1243	,1236
GSI-0203-04	1/8	3/16	1/4	,1269	,1251	,1878	,1873	,1243	,1236
GSI-0203-06	1/8	3/16	3/8	,1269	,1251	,1878	,1873	,1243	,1236
GSI-0304-04	3/16	1/4	1/4	,1892	,1873	,2503	,2497	,1865	,1858
GSI-0304-06	3/16	1/4	3/8	,1892	,1873	,2503	,2497	,1865	,1858
GSI-0304-08	3/16	1/4	1/2	,1892	,1873	,2503	,2497	,1865	,1858
GSI-0405-04	1/4	5/16	1/4	,2521	,2498	,3128	,3122	,2490	,2481
GSI-0405-05	1/4	5/16	5/16	,2521	,2498	,3128	,3122	,2490	,2481
GSI-0405-06	1/4	5/16	3/8	,2521	,2498	,3128	,3122	,2490	,2481
GSI-0405-08	1/4	5/16	1/2	,2521	,2498	,3128	,3122	,2490	,2481
GSI-0405-10	1/4	5/16	5/8	,2521	,2498	,3128	,3122	,2490	,2481
GSI-0405-12	1/4	5/16	3/4	,2521	,2498	,3128	,3122	,2490	,2481
GSI-0506-04	5/16	3/8	1/4	,3148	,3125	,3753	,3747	,3115	,3106
GSI-0506-06	5/16	3/8	3/8	,3148	,3125	,3753	,3747	,3115	,3106
GSI-0506-08	5/16	3/8	1/2	,3148	,3125	,3753	,3747	,3115	,3106
GSI-0506-12	5/16	3/8	3/4	,3148	,3125	,3753	,3747	,3115	,3106
GSI-0607-04	3/8	15/32	1/4	,3773	,3750	,4691	,4684	,3740	,3731
GSI-0607-06	3/8	15/32	3/8	,3773	,3750	,4691	,4684	,3740	,3731
GSI-0607-08	3/8	15/32	1/2	,3773	,3750	,4691	,4684	,3740	,3731
GSI-0607-12	3/8	15/32	3/4	,3773	,3750	,4691	,4684	,3740	,3731
GSI-0608-08	3/8	8/16	1/2	,3783	,3760	,5015	,5010	,3750	,3741
GSI-0608-12	3/8	8/16	3/4	,3773	,3750	,5015	,5010	,3750	,3741
GSI-0708-04	7/16	17/32	1/4	,4406	,4379	,5316	,5309	,4365	,4355
GSI-0708-08	7/16	17/32	1/2	,4406	,4379	,5316	,5309	,4365	,4355
GSI-0809-03	1/2	19/32	3/16	,5030	,5003	,5941	,5934	,4990	,4980

* nach dem Einpressen; Messverfahren ► Seite 59



Lieferzeit ab Lager



Preise Online-Preisliste

www.igus.de/de/g



zylindrische Gleitlager

Abmessungen [Inch]

Bestellnummer	d1	d2	b1	d1*		Einpressbohrung		Wellenmaße	
				max.	min.	max.	min.	max.	min.
GSI-0809-04	1/2	19/32	1/4	,5030	,5003	,5941	,5934	,4990	,4980
GSI-0809-06	1/2	19/32	3/8	,5030	,5003	,5941	,5934	,4990	,4980
GSI-0809-08	1/2	19/32	1/2	,5030	,5003	,5941	,5934	,4990	,4980
GSI-0809-10	1/2	19/32	5/8	,5030	,5003	,5941	,5934	,4990	,4980
GSI-0809-16	1/2	19/32	1	,5030	,5003	,5941	,5934	,4990	,4980
GSI-0810-08	1/2	5/8	1/2	,5040	,5013	,6260	,6250	,5000	,4990
GSI-0810-12	1/2	5/8	3/4	,5040	,5013	,6260	,6250	,5000	,4990
GSI-0910-06	9/16	21/32	3/8	,5655	,5627	,6566	,6559	,5615	,5605
GSI-0910-08	9/16	21/32	1/2	,5655	,5627	,6566	,6559	,5615	,5605
GSI-0910-10	9/16	21/32	5/8	,5655	,5627	,6566	,6559	,5615	,5605
GSI-1011-06	5/8	23/32	3/8	,6280	,6253	,7192	,7184	,6240	,6230
GSI-1011-08	5/8	23/32	1/2	,6280	,6253	,7192	,7184	,6240	,6230
GSI-1011-10	5/8	23/32	5/8	,6280	,6253	,7192	,7184	,6240	,6230
GSI-1011-12	5/8	23/32	3/4	,6280	,6253	,7192	,7184	,6240	,6230
GSI-1011-16	5/8	23/32	1	,6280	,6253	,7192	,7184	,6240	,6230
GSI-1011-20	5/8	23/32	1 1/4	,6280	,6253	,7192	,7184	,6240	,6230
GSI-1011-30	5/8	23/32	1 7/8	,6280	,6253	,7192	,7184	,6240	,6230
GSI-1012-08	5/8	3/4	1/2	,6290	,6263	,7510	,7500	,6250	,6240
GSI-1012-16	5/8	3/4	1	,6290	,6263	,7510	,7500	,6250	,6240
GSI-1112-14	11/16	25/32	7/8	,6906	,6879	,7817	,7809	,6865	,6855
GSI-1214-02	3/4	7/8	1/8	,7541	,7505	,8755	,8747	,7491	,7479
GSI-1214-06	3/4	7/8	3/8	,7541	,7505	,8755	,8747	,7491	,7479
GSI-1214-08	3/4	7/8	1/2	,7541	,7505	,8755	,8747	,7491	,7479
GSI-1214-12	3/4	7/8	3/4	,7541	,7505	,8755	,8747	,7491	,7479
GSI-1214-16	3/4	7/8	1	,7541	,7505	,8755	,8747	,7491	,7479
GSI-1214-20	3/4	7/8	1 1/4	,7541	,7505	,8755	,8747	,7491	,7479
GSI-1214-24	3/4	7/8	1 1/2	,7541	,7505	,8755	,8747	,7491	,7479
GSI-1416-06	7/8	1	3/8	,8791	,8757	1,0005	,9997	,8741	,8729
GSI-1416-08	7/8	1	1/2	,8791	,8757	1,0005	,9997	,8741	,8729
GSI-1416-10	7/8	1	5/8	,8791	,8757	1,0005	,9997	,8741	,8729
GSI-1416-12	7/8	1	3/4	,8791	,8757	1,0005	,9997	,8741	,8729
GSI-1416-16	7/8	1	1	,8791	,8757	1,0005	,9997	,8741	,8729
GSI-1416-24	7/8	1	1 1/2	,8791	,8757	1,0005	,9997	,8741	,8729
GSI-1618-08	1	1 1/8	1/2	1,0041	1,0007	1,1255	1,1247	,9991	,9979
GSI-1618-12	1	1 1/8	3/4	1,0041	1,0007	1,1255	1,1247	,9991	,9979
GSI-1618-16	1	1 1/8	1	1,0041	1,0007	1,1255	1,1247	,9991	,9979
GSI-1618-20	1	1 1/8	1 1/4	1,0041	1,0007	1,1255	1,1247	,9991	,9979
GSI-1618-24	1	1 1/8	1 1/2	1,0041	1,0007	1,1255	1,1247	,9991	,9979
GSI-1618-33	1	1 1/8	2 1/16	1,0041	1,0007	1,1255	1,1247	,9991	,9979
GSI-1820-12	1 1/8	1 9/32	3/4	1,1288	1,1254	1,2818	1,2808	1,1238	1,1226
GSI-1820-24	1 1/8	1 9/32	1 1/2	1,1288	1,1254	1,2818	1,2808	1,1238	1,1226
GSI-2022-12	1 1/4	1 13/32	3/4	1,2548	1,2508	1,4068	1,4058	1,2488	1,2472

* nach dem Einpressen; Messverfahren ► Seite 59



zylindrische Gleitlager

Abmessungen [Inch]

Bestellnummer	d1	d2	b1	d1*		Einpressbohrung		Wellenmaße	
				max.	min.	max.	min.	max.	min.
GSI-2022-14	1 1/4	1 13/32	7/8	1,2548	1,2508	1,4068	1,4058	1,2488	1,2472
GSI-2022-16	1 1/4	1 13/32	1	1,2548	1,2508	1,4068	1,4058	1,2488	1,2472
GSI-2022-20	1 1/4	1 13/32	1 1/4	1,2548	1,2508	1,4068	1,4058	1,2488	1,2472
GSI-2022-24	1 1/4	1 13/32	1 1/2	1,2548	1,2508	1,4068	1,4058	1,2488	1,2472
GSI-2224-16	1 3/8	1 17/32	1	1,3798	1,3758	1,5318	1,5308	1,3738	1,3722
GSI-2224-24	1 3/8	1 17/32	1 1/2	1,3798	1,3758	1,5318	1,5308	1,3738	1,3722
GSI-2224-26	1 3/8	1 17/32	1 5/8	1,3798	1,3758	1,5318	1,5308	1,3738	1,3722
GSI-2426-06	1 1/2	1 21/32	3/8	1,5048	1,5008	1,6568	1,6558	1,4988	1,4972
GSI-2426-07	1 1/2	1 21/32	7/16	1,5048	1,5008	1,6568	1,6558	1,4988	1,4972
GSI-2426-08	1 1/2	1 21/32	1/2	1,5048	1,5008	1,6568	1,6558	1,4988	1,4972
GSI-2426-12	1 1/2	1 21/32	3/4	1,5048	1,5008	1,6568	1,6558	1,4988	1,4972
GSI-2426-16	1 1/2	1 21/32	1	1,5048	1,5008	1,6568	1,6558	1,4988	1,4972
GSI-2426-24	1 1/2	1 21/32	1 1/2	1,5048	1,5008	1,6568	1,6558	1,4988	1,4972
GSI-2629-20	1 5/8	1 25/32	1 1/4	1,6297	1,6258	1,7818	1,7808	1,6238	1,6222
GSI-2831-16	1 3/4	1 15/16	1	1,7547	1,7505	1,9381	1,9371	1,7487	1,7471
GSI-2831-24	1 3/4	1 15/16	1 1/2	1,7547	1,7505	1,9381	1,9371	1,7487	1,7471
GSI-2831-32	1 3/4	1 15/16	2	1,7547	1,7505	1,9381	1,9371	1,7487	1,7471
GSI-2831-40	1 3/4	1 15/16	2 1/2	1,7547	1,7505	1,9381	1,9371	1,7487	1,7471
GSI-2831-48	1 3/4	1 15/16	3	1,7547	1,7505	1,9381	1,9371	1,7487	1,7471
GSI-3235-16	2	2 3/16	1	2,0057	2,0011	2,1883	2,1871	1,9981	1,9969
GSI-3235-24	2	2 3/16	1 1/2	2,0057	2,0011	2,1883	2,1871	1,9981	1,9969
GSI-3235-32	2	2 3/16	2	2,0057	2,0011	2,1883	2,1871	1,9981	1,9969
GSI-3639-32	2 1/4	2 7/16	2	2,2577	2,2531	2,4377	2,4365	2,2507	2,2489
GSI-4043-32	2 2/4	2 11/16	2	2,5082	2,5035	2,6881	2,6869	2,5000	2,4999
GSI-4447-32	2 3/4	2 15/16	2	2,7570	2,7523	2,9370	2,9358	2,7500	2,7490
GSI-4851-32	3	3 3/16	2	3,0070	3,0023	3,1870	3,1858	3,0000	2,9990

* nach dem Einpressen; Messverfahren ► Seite 59

iglidur® G | Lieferprogramm | Inch

Gleitlager mit Bund

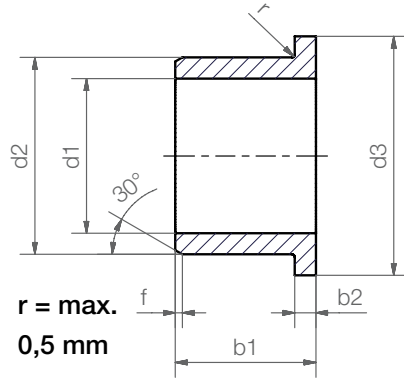

Bestellschlüssel

GFI-0203-02



- Gesamtlänge b1
- Außendurchmesser d2
- Innendurchmesser d1
- Inch
- mit Bund (Form F)
- Werkstoff iglidur® G

Fase in Abhängigkeit von d1

d1 [Inch]:	Ø 0,040–0,236	Ø 0,236–0,472	Ø 0,472–1,18	Ø > 1,18
f [Inch]:	0,012	0,019	0,031	0,047

Abmessungen [Inch]

Bestellnummer	d1	d2	b1	d3	b2	d1*		Einpressbohrung		Wellenmaße	
						max.	min.	max.	min.	max.	min.
GFI-0203-02	1/8	3/16	1/8	,312	,032	,1269	,1251	,1878	,1873	,1243	,1236
GFI-0203-03	1/8	3/16	3/16	,312	,032	,1269	,1251	,1878	,1873	,1243	,1236
GFI-0203-04	1/8	3/16	1/4	,312	,032	,1269	,1251	,1878	,1873	,1243	,1236
GFI-0203-06	1/8	3/16	3/8	,312	,032	,1269	,1251	,1878	,1873	,1243	,1236
GFI-0304-04	3/16	1/4	1/4	,375	,032	,1892	,1873	,2503	,2497	,1865	,1858
GFI-0304-06	3/16	1/4	3/8	,375	,032	,1892	,1873	,2503	,2497	,1865	,1858
GFI-0304-08	3/16	1/4	1/2	,375	,032	,1892	,1873	,2503	,2497	,1865	,1858
GFI-0405-04	1/4	5/16	1/4	,500	,032	,2521	,2498	,3128	,3122	,2490	,2481
GFI-0405-05	1/4	5/16	5/16	,500	,032	,2521	,2498	,3128	,3122	,2490	,2481
GFI-0405-06	1/4	5/16	3/8	,500	,032	,2521	,2498	,3128	,3122	,2490	,2481
GFI-0405-08	1/4	5/16	1/2	,500	,032	,2521	,2498	,3128	,3122	,2490	,2481
GFI-0405-12	1/4	5/16	3/4	,500	,032	,2521	,2498	,3128	,3122	,2490	,2481
GFI-0506-04	5/16	3/8	1/4	,562	,032	,3148	,3125	,3753	,3747	,3115	,3106
GFI-0506-06	5/16	3/8	3/8	,562	,032	,3148	,3125	,3753	,3747	,3115	,3106
GFI-0506-08	5/16	3/8	1/2	,562	,032	,3148	,3125	,3753	,3747	,3115	,3106
GFI-0506-12	5/16	3/8	3/4	,562	,032	,3148	,3125	,3753	,3747	,3115	,3106
GFI-0607-04	3/8	15/32	1/4	,687	,046	,3773	,3750	,4691	,4684	,3740	,3731
GFI-0607-05	3/8	15/32	5/16	,687	,046	,3773	,3750	,4691	,4684	,3740	,3731
GFI-0607-06	3/8	15/32	3/8	,687	,046	,3773	,3750	,4691	,4684	,3740	,3731
GFI-0607-08	3/8	15/32	1/2	,687	,046	,3773	,3750	,4691	,4684	,3740	,3731
GFI-0607-12	3/8	15/32	3/4	,687	,046	,3773	,3750	,4691	,4684	,3740	,3731
GFI-0607-14	3/8	15/32	7/8	,687	,046	,3773	,3750	,4691	,4684	,3740	,3731
GFI-0708-04	7/16	17/32	1/4	,750	,046	,4406	,4379	,5316	,5309	,4365	,4355
GFI-0708-08	7/16	17/32	1/2	,750	,046	,4406	,4379	,5316	,5309	,4365	,4355
GFI-0809-04	1/2	19/32	1/4	,875	,046	,5030	,5003	,5941	,5934	,4990	,4980

* nach dem Einpressen; Messverfahren ► Seite 59

Lieferzeit ab Lager

Preise Online-Preisliste
www.igus.de/de/g



Gleitlager mit Bund

Abmessungen [Inch]

Bestellnummer	d1	d2	b1	d3	b2	d1*		Einpressbohrung		Wellenmaße	
						max.	min.	max.	min.	max.	min.
GFI-0809-05	1/2	19/32	5/16	,875	,046	,5030	,5003	,5941	,5934	,4990	,4980
GFI-0809-06	1/2	19/32	3/8	,875	,046	,5030	,5003	,5941	,5934	,4990	,4980
GFI-0809-08	1/2	19/32	1/2	,875	,046	,5030	,5003	,5941	,5934	,4990	,4980
GFI-0809-12	1/2	19/32	3/4	,875	,046	,5030	,5003	,5941	,5934	,4990	,4980
GFI-0809-16	1/2	19/32	1	,875	,046	,5030	,5003	,5941	,5934	,4990	,4980
GFI-1011-06	5/8	23/32	3/8	,937	,046	,6280	,6253	,7192	,7184	,6240	,6230
GFI-1011-08	5/8	23/32	1/2	,937	,046	,6280	,6253	,7192	,7184	,6240	,6230
GFI-1011-12	5/8	23/32	3/4	,937	,046	,6280	,6253	,7192	,7184	,6240	,6230
GFI-1011-14	5/8	23/32	7/8	,937	,046	,6280	,6253	,7192	,7184	,6240	,6230
GFI-1011-16	5/8	23/32	1	,937	,046	,6280	,6253	,7192	,7184	,6240	,6230
GFI-1011-24	5/8	23/32	1 1/2	,937	,046	,6280	,6253	,7192	,7184	,6240	,6230
GFI-1214-02	3/4	7/8	1/8	1,125	,062	,7541	,7505	,8755	,8747	,7491	,7479
GFI-1214-06	3/4	7/8	3/8	1,125	,062	,7541	,7505	,8755	,8747	,7491	,7479
GFI-1214-08	3/4	7/8	1/2	1,125	,062	,7541	,7505	,8755	,8747	,7491	,7479
GFI-1214-10	3/4	7/8	5/8	1,125	,062	,7541	,7505	,8755	,8747	,7491	,7479
GFI-1214-12	3/4	7/8	3/4	1,125	,062	,7541	,7505	,8755	,8747	,7491	,7479
GFI-1214-16	3/4	7/8	1	1,125	,062	,7541	,7505	,8755	,8747	,7491	,7479
GFI-1214-24	3/4	7/8	1 1/2	1,125	,062	,7541	,7505	,8755	,8747	,7491	,7479
GFI-1416-08	7/8	1	1/2	1,250	,062	,8791	,8757	1,0005	,9997	,8741	,8729
GFI-1416-12	7/8	1	3/4	1,250	,062	,8791	,8757	1,0005	,9997	,8741	,8729
GFI-1416-16	7/8	1	1	1,250	,062	,8791	,8757	1,0005	,9997	,8741	,8729
GFI-1416-20	7/8	1	1 1/4	1,250	,062	,8791	,8757	1,0005	,9997	,8741	,8729
GFI-1416-24	7/8	1	1 1/2	1,250	,062	,8791	,8757	1,0005	,9997	,8741	,8729
GFI-1618-08	1	1 1/8	1/2	1,375	,062	1,0041	1,0007	1,1255	1,1247	,9991	,9979
GFI-1618-12	1	1 1/8	3/4	1,375	,062	1,0041	1,0007	1,1255	1,1247	,9991	,9979
GFI-1618-16	1	1 1/8	1	1,375	,062	1,0041	1,0007	1,1255	1,1247	,9991	,9979
GFI-1618-20	1	1 1/8	1 1/4	1,375	,062	1,0041	1,0007	1,1255	1,1247	,9991	,9979
GFI-1618-24	1	1 1/8	1 1/2	1,375	,062	1,0041	1,0007	1,1255	1,1247	,9991	,9979
GFI-1820-12	1 1/8	1 9/32	3/4	1,562	,078	1,1288	1,1254	1,2818	1,2808	1,1238	1,1226
GFI-1820-24	1 1/8	1 9/32	1 1/2	1,562	,078	1,1288	1,1254	1,2818	1,2808	1,1238	1,1226
GFI-2022-06	1 1/4	1 13/32	3/8	1,687	,078	1,2548	1,2508	1,4068	1,4058	1,2488	1,2472
GFI-2022-12	1 1/4	1 13/32	3/4	1,687	,078	1,2548	1,2508	1,4068	1,4058	1,2488	1,2472
GFI-2022-14	1 1/4	1 13/32	7/8	1,687	,078	1,2548	1,2508	1,4068	1,4058	1,2488	1,2472
GFI-2022-16	1 1/4	1 13/32	1	1,687	,078	1,2548	1,2508	1,4068	1,4058	1,2488	1,2472
GFI-2022-20	1 1/4	1 13/32	1 1/4	1,687	,078	1,2548	1,2508	1,4068	1,4058	1,2488	1,2472
GFI-2022-24	1 1/4	1 13/32	1 1/2	1,687	,078	1,2548	1,2508	1,4068	1,4058	1,2488	1,2472
GFI-2224-16	1 3/8	1 17/32	1	1,875	,078	1,3798	1,3758	1,5318	1,5308	1,3738	1,3722
GFI-2426-12	1 1/2	1 21/32	3/4	2,000	,078	1,5048	1,5008	1,6568	1,6558	1,4988	1,4972
GFI-2426-16	1 1/2	1 21/32	1	2,000	,078	1,5048	1,5008	1,6568	1,6558	1,4988	1,4972
GFI-2426-24	1 1/2	1 21/32	1 1/2	2,000	,078	1,5048	1,5008	1,6568	1,6558	1,4988	1,4972
GFI-2831-16	1 3/4	1 15/16	1	2,375	,093	1,7547	1,7505	1,9381	1,9371	1,7487	1,7471
GFI-2831-24	1 3/4	1 15/16	1 1/2	2,375	,093	1,7547	1,7505	1,9381	1,9371	1,7487	1,7471

* nach dem Einpressen; Messverfahren ► Seite 59



Gleitlager mit Bund

Abmessungen [Inch]

Bestellnummer	d1	d2	b1	d3	b2	d1*		Einpressbohrung		Wellenmaße	
						max.	min.	max.	min.	max.	min.
GFI-2831-32	1 3/4	1 15/16	2	2,375	,093	1,7547	1,7505	1,9381	1,9371	1,7487	1,7471
GFI-3235-16	2	2 3/16	1	2,625	,093	2,0057	2,0011	2,1883	2,1871	1,9981	1,9969
GFI-3235-24	2	2 3/16	1 1/2	2,625	,093	2,0057	2,0011	2,1883	2,1871	1,9981	1,9969
GFI-3235-32	2	2 3/16	2	2,625	,093	2,0057	2,0011	2,1883	2,1871	1,9981	1,9969
GFI-3639-32	2 1/4	2 7/16	2	2,750	,093	2,2577	2,2531	2,4377	2,4365	2,2507	2,2489
GFI-4043-32	2 1/2	2 11/16	2	3,125	,093	2,5082	2,5035	2,6881	2,6869	2,5000	2,4999
GFI-4447-32	2 3/4	2 15/16	2	3,375	,093	2,7570	2,7523	2,9370	2,9358	2,7500	2,7490

* nach dem Einpressen; Messverfahren ► Seite 59



Lieferzeit ab Lager



Preise Online-Preisliste
www.igus.de/de/g

Anlaufscheiben

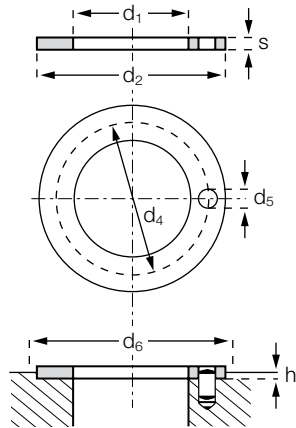

Bestellschlüssel

GTI-0814-01



- Höhe s
- Außendurchmesser d2
- Innendurchmesser d1
- Inch
- Anlaufscheiben (Form T)
- Werkstoff iglidur® G

Abmessungen nach ISO 3547-1 und Sonderabmessungen

Abmessungen [Inch]

Bestellnummer	d1 +,010	d2 -,010	s -,0020	d4 ±,005	d5 ,015 + ,005	h +,008	d6 +,005
GTI-0814-01	,500	,875	,0585	,692	,067	,040	,875
GTI-1018-01	,625	1,125	,0585	,880	,099	,040	1,125
GTI-1220-01	,750	1,250	,0585	1,005	,099	,040	1,250
GTI-1424-01	,875	1,500	,0585	1,192	,130	,040	1,500
GTI-1628-01	1,000	1,750	,0585	1,380	,130	,040	1,750
GTI-2034-01	1,250	2,125	,0585	1,692	,161	,040	2,125
GTI-2440-01	1,500	2,500	,0585	2,005	,192	,040	2,500
GTI-2844-01	1,750	2,750	,0585	2,255	,192	,040	2,750
GTI-3248-01	2,000	3,000	,0895	2,505	,192	,070	3,000

* nach dem Einpressen; Messverfahren ► Seite 59



Lieferzeit ab Lager



Preise Online-Preisliste
www.igus.de/de/g